

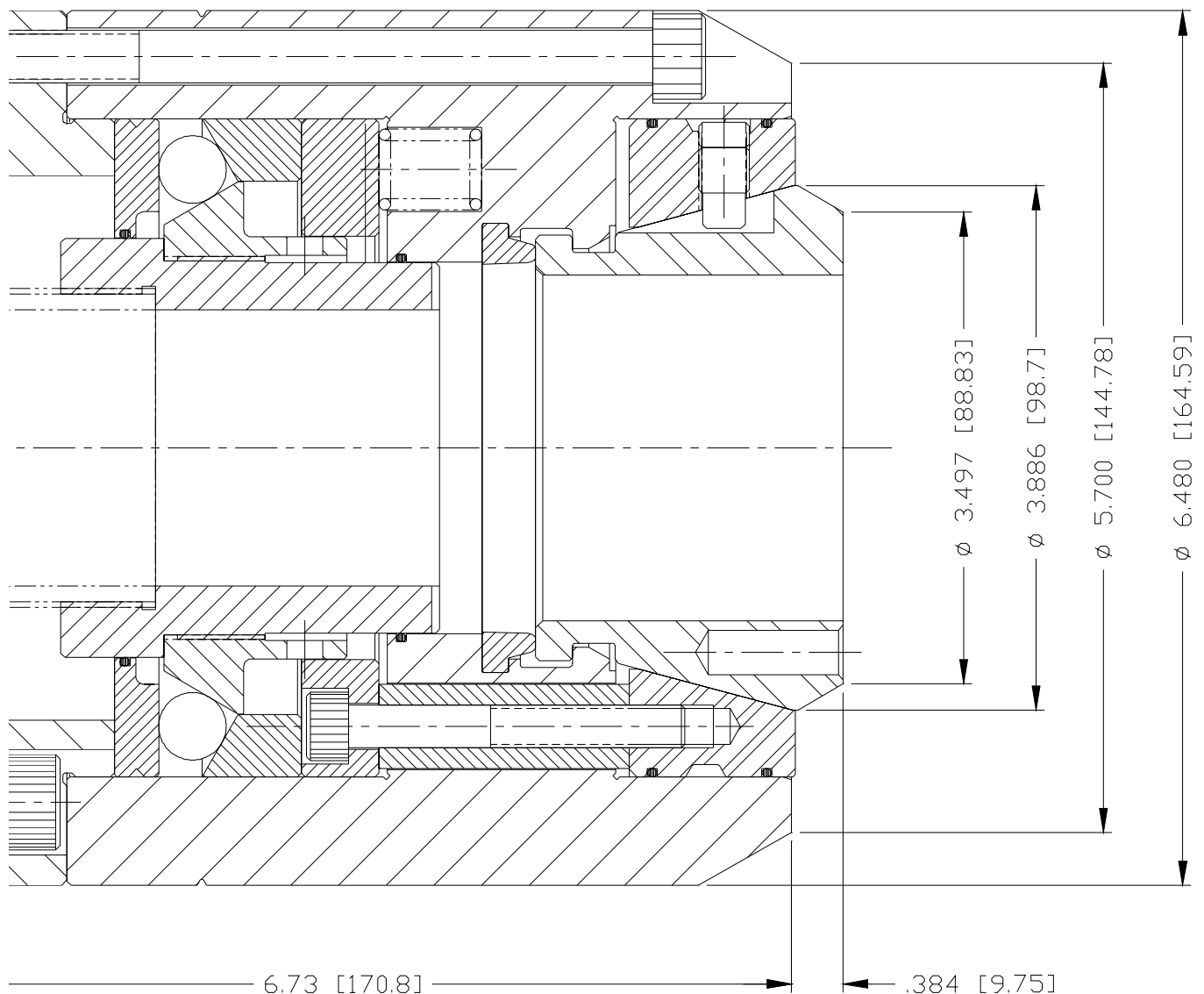

# Technical Documentation for CB-NDR Pull to Close Dead Length Collet Chucks



## 1.0 TABLE OF CONTENTS

1.0	Contact & Service Information	1
2.0	Introduction	2
3.0	Precautions for Safe Operation	3
4.0	Recommended Tightening Torque for Mounting Screws	7
5.0	Chucking Guidelines	
5.1	Accuracy & Runout	8
5.2	Clamping Force	9
5.3	Clamping Short Workpieces	9
5.4	End Location of Workpiece	10
5.5	Centrifugal Force	10
6.0	Collet Models, Specifications, & Capacities	
6.1	Quick Change Collets	11
6.2	"S" Pad Master Collets	11
7.0	Collet Chuck Models & Specifications	
7.1	Quick Change Collet Chucks	12
7.2	"S" Pad Collet Chucks	12
8.0	Collet Chuck Assembly Drawing & Parts Lists	12
9.0	Collet Chuck Installation	
9.1	Mounting Adapter Plate	15
9.2	Mounting Collet Chuck Assembly	16
10.0	Quick Change Collet Installation & Changeover	
10.1	Quick Change Collet Installation	17
10.2	Quick Change Collet Removal	17
11.0	"S" Pad Master Collet Installation & Removal	
11.1	"S" Pad Master Collet Installation	18
11.2	"S" Pad Master Collet Removal	18
12.0	Changing Fixture Assembly Drawings & Parts Lists	
12.1	Manual Changing Fixtures	19
12.2	Pneumatic Changing Fixtures	20
13.0	Trouble Shooting Guide	21
14.0	Spindle Data Sheet	22

## 1.0 CONTACT & SERVICE INFORMATION

### Manufactured by:

MicroCentric Corp.  
Plainview, NY USA

### Service in North America:

MicroCentric Corp.  
25 Terminal Drive  
Plainview, NY 11803  
Tel: 1-800-573-1139 (toll free)  
1-516-349-7220  
Fax: 1-516-349-9354  
E-mail: sales@microcentric.com

### Service in Europe:

MicroCentric GmbH  
Auf der Hub 9  
D-70439 Stuttgart  
Germany  
Tel: 49-711-9809240  
Fax: 49-711-802483  
E-mail: info@microcentric.de

### Service in Asia:

Dynamic Tools Corp.  
3-3-13 Saikujo-cho  
Nara 630  
Japan  
Tel: 81-742-62-6760  
Fax: 81-742-62-6766  
E-mail: dynex@earth.email.ne.jp

## 2.0 INTRODUCTION

MicroCentric Collet Chucks offer unmatched accuracy and long term performance. The information contained in this manual, if properly followed, will enable you to take full advantage of your chuck's capabilities.

We recommend you read through this entire manual to familiarize yourself with the installation and operation of MicroCentric collet chucks before installing and using your chuck. We also suggest you keep this manual at hand for future reference.

	<b>Safety Alert Symbol</b>
<p>This is the industry "Safety Alert Symbol". This symbol is used to call your attention to items or operations that could be dangerous to you or persons using this equipment. Please read these messages and follow these instructions carefully. It is essential that you read the instructions and safety regulations before you attempt to assembly or use this unit.</p>	

	<b>DANGER</b>
--	---------------

**Indicates an imminent hazardous condition which, if not avoided, could result in serious injury or death.**

	<b>WARNING</b>
---	----------------

**Indicates a potentially hazardous condition which, if not avoided, could result in serious injury or death.**

	<b>CAUTION</b>
---	----------------

**Indicates a potentially hazardous condition which, if not avoided, could result in minor or moderate injury.**

<b>IMPORTANT</b>
------------------

**Instructions for optimum chuck performance and avoiding errors or misuse of chuck.**

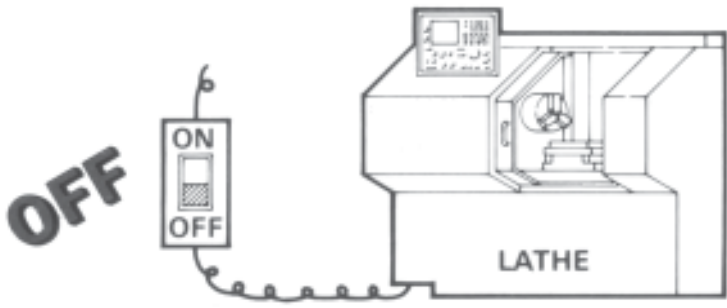

### 3.0 PRECAUTIONS FOR SAFE OPERATION

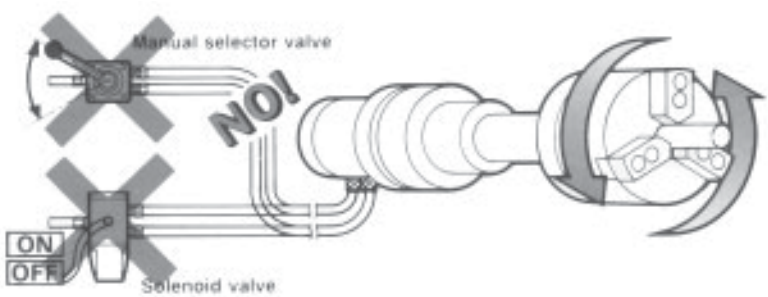
 <p><b>DANGER</b></p>	<p>Switch off power to the machine before installing, or changing the chuck.</p>
<p>The machine spindle may inadvertently be switched on, and the turret indexed or jogged potentially causing serious injury to the operator.</p>	

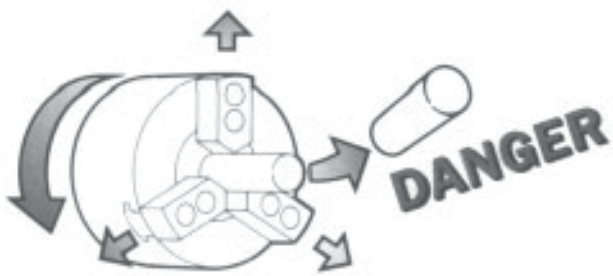
 <p><b>DANGER</b></p>	<p>Do not operate the control valve (foot pedal) or solenoid valve during spindle rotation.</p>
<p>The workpiece will be thrown from the chuck potentially causing serious injury to the operator.</p>	

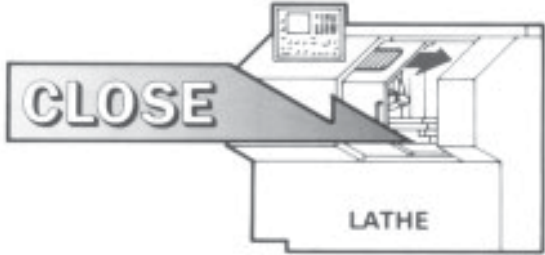

 <p><b>DANGER</b></p>	<p>Do not exceed the maximum recommended speed of the chuck for a given input pressure (draw tube force).</p>
<p>The workpiece can be thrown from the chuck due to inadequate gripping force as a result of centrifugal force.</p>	

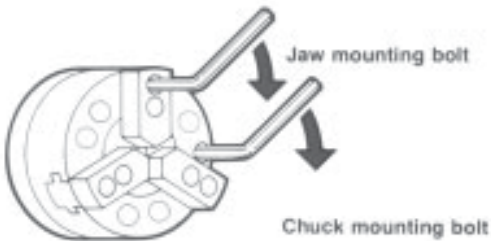

 <b>WARNING</b>	<b>Do not start the machine with the door open.</b>
<p>The operator could be injured by cutting chips or other flying debris.</p>	

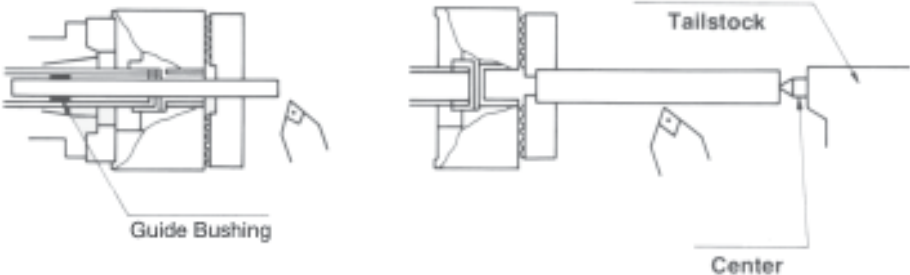
 <b>WARNING</b>	<b>Do not exceed the maximum recommended input force (draw tube force) for a specific chuck model.</b>
<p>The workpiece can be thrown from the chuck as a result of damage to the chuck's actuating mechanism.</p>	



 <b>WARNING</b>	<b>Make certain the mounting bolts are securely tightened to the recommended torque values.</b>
<p>The chuck could become loose during operation causing damage to the chuck and potentially throwing the workpiece from the chuck.</p>	

 <b>WARNING</b>	<b>Long workpieces should be supported by a live center in the tail stock or by a steady rest.</b>
The workpiece can be thrown from the chuck if it is too long and not properly supported.	

 <b>CAUTION</b>	<b>Never hit the outside of the chuck, the tapered sleeve, or the workpiece with a hammer</b>
The workpiece can be thrown from the chuck if the chuck is damaged.	

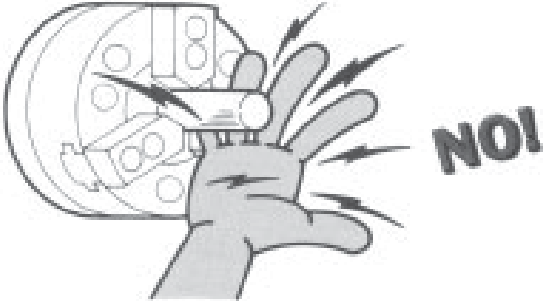
 <b>WARNING</b>	<b>Do not attempt to modify the chuck or any of its' components.</b>
The workpiece can be thrown from the chuck due to damage which may be caused to the chuck.	

 <b>CAUTION</b>	<b>Always make sure to keep your hands and fingers clear of the collet and workpiece as the chuck is clamped.</b>
<p>The operator can be seriously injured if a finger or hand is clamped between the top jaw and workpiece.</p>	

 <b>WARNING</b>	<b>Never attempt to operate a machine tool while under the influence of drugs or alcohol.</b>
<p>Damage to the machine, tooling, and chuck, or serious injury to the operator could result.</p>	

 <b>WARNING</b>	<b>Never wear gloves, loose clothing, or ties while operating a machine tool.</b>
<p>Gloves, loose clothing, and ties can become caught in the chuck causing serious injury to the operator as the spindle is rotated.</p>	

#### 4.0 RECOMMENDED TIGHTENING TORQUE FOR MOUNTING SCREWS

Screw Size	Tightening Torque	
<b>M5</b>	7.0 lb-ft	9.5 N-m
<b>M6</b>	9.4 lb-ft	12.7 N-m
<b>M8</b>	28.2 lb-ft	38.2 N-m
<b>M10</b>	53.5 lb-ft	72.6 N-m
<b>M12</b>	78.8 lb-ft	106.8 N-m
<b>M14</b>	125.8 lb-ft	170.6 N-m
<b>M16</b>	184.4 lb-ft	250.0 N-m
<b>M20</b>	296.6 lb-ft	402.1 N-m

## 5.0 CHUCKING GUIDELINES

### 5.1 ACCURACY AND RUNOUT

To obtain high accuracy workholding it is important to correctly match the collet diameter to the workpiece diameter being clamped. Each workpiece has a dimensional tolerance, and to achieve best chucking accuracy the collet should be sized to correspond to the largest diameter of the workpiece's range. Figure 5.1 illustrates the principle of single line contact by each collet segment. This condition will enable you to obtain minimum workpiece runout.

When a workpiece is clamped by a collet that has a diameter that is smaller than the workpiece diameter, the condition shown in figure 5.2 will result. This will produce higher clamping force on the workpiece, however, accuracy will be sacrificed.

Even when close chucking accuracy is not required, it is always important to use a collet with the proper bore size for each workpiece or bar stock. Following this principle will maximize the overall performance of the collet chuck system.

In order to obtain close chucking accuracy, the collet's surfaces must be kept clean and free from chip buildup. On long running operations it is recommended that the collet be removed periodically for cleaning.

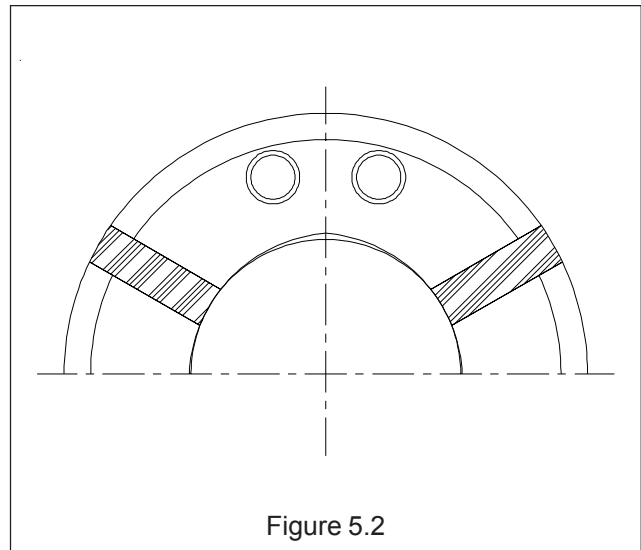
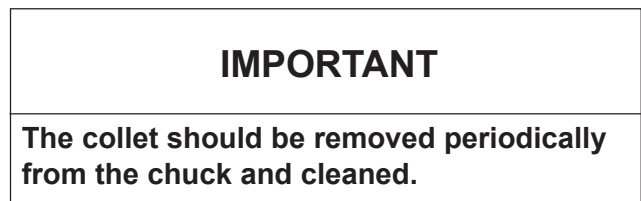
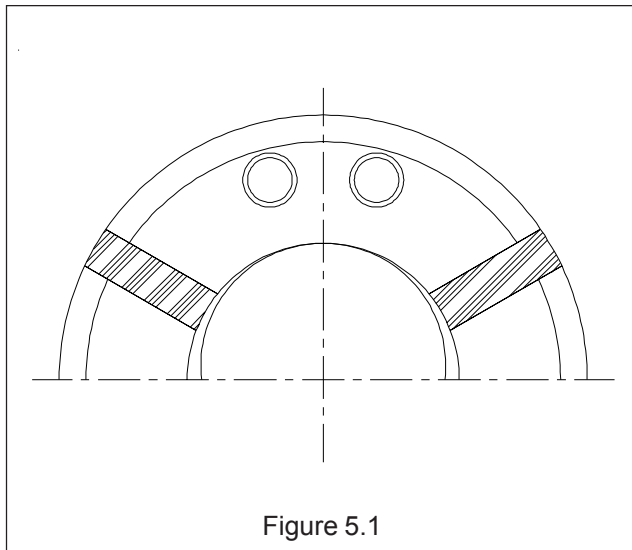

## 5.2 CLAMPING FORCE

Higher clamping force is generally required for roughing applications as compared to finishing operations. The clamping characteristics of a collet are enhanced by serrations, which will permitted higher rates of metal removal at the same draw tube force as compared to a smooth bore collet. The frictional force between the collet and workpiece or bar stock can also be increased by applying a carbide grit or diamond particle plating to the clamping surface of the collet. Sharp serrations that penetrate the surface of the workpiece provide the greatest clamping force to prevent workpiece slippage. Collets with widely spaced serrations also have enhanced clamping capability. The appropriate collet configuration for a given application is determined by a number of factors including cutting forces, spindle speed, and the material of the workpiece or bar stock. Recommendations for a specific applications can be obtained by calling MicroCentric's technical sales staff.

## 5.3 CLAMPING SHORT WORKPIECES

If the clamping length of a workpiece is .312" (8mm) or less, it is necessary to use a reduced nose collet. Figure 9.3 shows a reduced nose collet with a banking step clamping a short workpiece.

To accurately clamp short workpieces, the part must be located against a banking step in the collet (on dead length chucks) or against a part stop mounted inside the chuck body. In order to clamp short workpieces with minimum runout, the workpiece must have a square face to locate against.

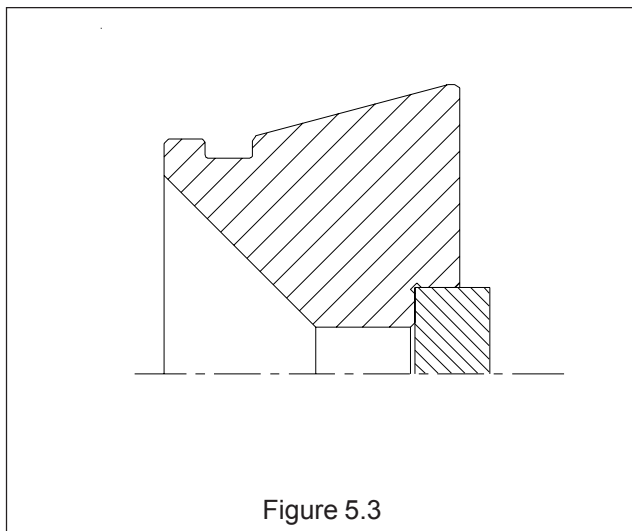

### WARNING

**Do not exceed the maximum recommended draw tube force for a specific collet chuck model.**



### CAUTION

**Whenever the clamping length of a workpiece is .312" (8mm) or less, it is necessary to use a reduced nose collet.**

### 5.4 END STOPPING A WORKPIECE

When using a dead length style collet chuck, a workpiece can also be end stopped on a banking face machined in the bore a collet, as shown in figure 5.3, or on the front face of a collet as shown in figure 5.4.

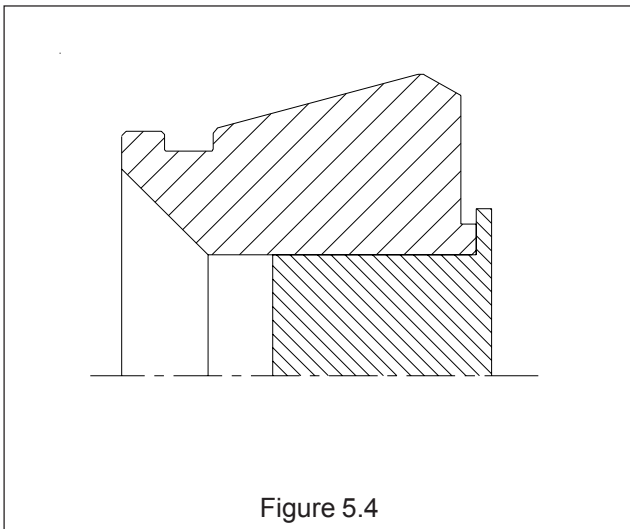
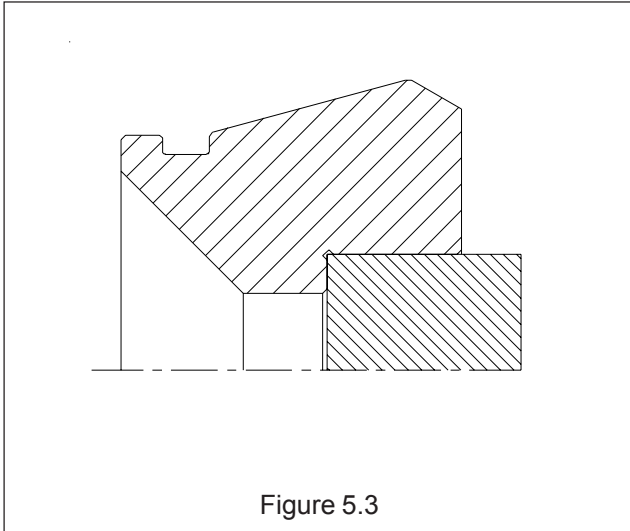

### 5.5 CENTRIFUGAL FORCE

The clamping force of a collet is affected by centrifugal force as spindle speed increases. Never exceed the maximum spindle speed recommended for a specific collet chuck model.

The loss of clamping force at high spindle speeds can be minimized by reducing the weight of a collet. Excess weight can be removed from a collet by drilling holes into the front face. For some high speed applications it may be necessary to dynamically balance the collet chuck. Consult MicroCentric's technical sales staff for further information.



#### WARNING

Do not exceed the maximum recommended spindle speed for a specific collet chuck model.



#### CAUTION

Collet chucks running at speeds above 4,000 rpm may need to be dynamically balanced.

## 6.0 COLLET MODELS & SPECIFICATIONS

### 6.1 QUICK CHANGE COLLETS

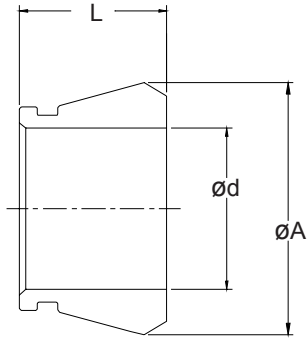

Collet Model	ød Max.	øA	L	Range
SK65BZI	2.625"	3.917"	2.284"	+/- .020"
	66mm	99.5mm	58mm	+/- 0.5mm

### 6.2 "S" PAD MASTER COLLETS

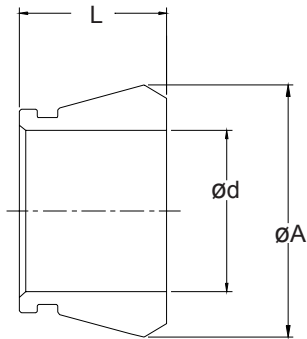

Master Collet	Collet Pad	ød Max.	L	Range
SK65BZI/S20	S-20	2.000"	2.284"	+/- .020"
		50.8mm	58mm	+/- 0.5mm
SK65BZI/S22	S-22	2.250"	2.323"	+/- .020"
		57.2mm	59mm	+/- 0.5mm
SK80BZI/S26	S-26	2.625"	1.850"	+/- .030"
		66mm	47mm	+/- 0.75mm
SK80BZI/S30	S-30	3.000"	1.850"	+/- .030"
		76.2mm	47mm	+/- 0.75mm

#### Vulcanized Rubber

MicroCentric Quick Change and "S" Pad Master Collets are hardened and precision ground segments held together by vulcanized rubber.

MicroCentric's vulcanizing technology produces a permanent bond between rubber and metal. However, if the rubber becomes damaged during normal use, the collet can be returned to MicroCentric and revulcanized. Contact one of our technical sales associates for information and cost.

## 7.0 COLLET CHUCK MODELS & SPECIFICATIONS

### 7.1 QUICK CHANGE COLLET CHUCKS

<b>Chuck Model</b>	<b>CB65-NDR</b>
<b>Collet Model</b>	SK65BZI
<b>Through Capacity</b>	2.625"
	66mm
<b>Clamping Range</b>	+/- .020"
	+/- 0.5mm
<b>Draw Tube Stroke</b>	.160"
	4mm
<b>Max. Draw Tube Force</b>	7,060 lbs
	3,210 kg
<b>Max. Clamping Force</b>	12,115 lbs
	5,510 kg
<b>Max. Spindle Speed</b>	5,000 rpm

### 7.1 "S" PAD COLLET CHUCKS

<b>Chuck Model</b>	<b>CB65-NDR</b>	<b>CB80-NDR</b>
<b>Master Collet Model</b>	SK65BZI/S20-S22	SK80BZI/S26-S30
<b>Through Capacity</b>	2.000"/2.250"	2.625"/3.000"
	50.8mm/57.2mm	66.7mm/76.2mm
<b>Clamping Range</b>	+/- .020"	+/- .020"
	+/- 0.5mm	+/- 0.5mm
<b>Draw Tube Stroke</b>	.160"	.160"
	4mm	4mm
<b>Max. Draw Tube Force</b>	7,060 lbs	7,770 lbs
	3,210 kg	3,530 kg
<b>Max. Clamping Force</b>	12,115 lbs	13,330 lbs
	5,510 kg	6,060 kg
<b>Max. Spindle Speed</b>	5,000 rpm	4,500 rpm

## 8.0 COLLET CHUCK ASSEMBLY DRAWING AND PARTS LISTS

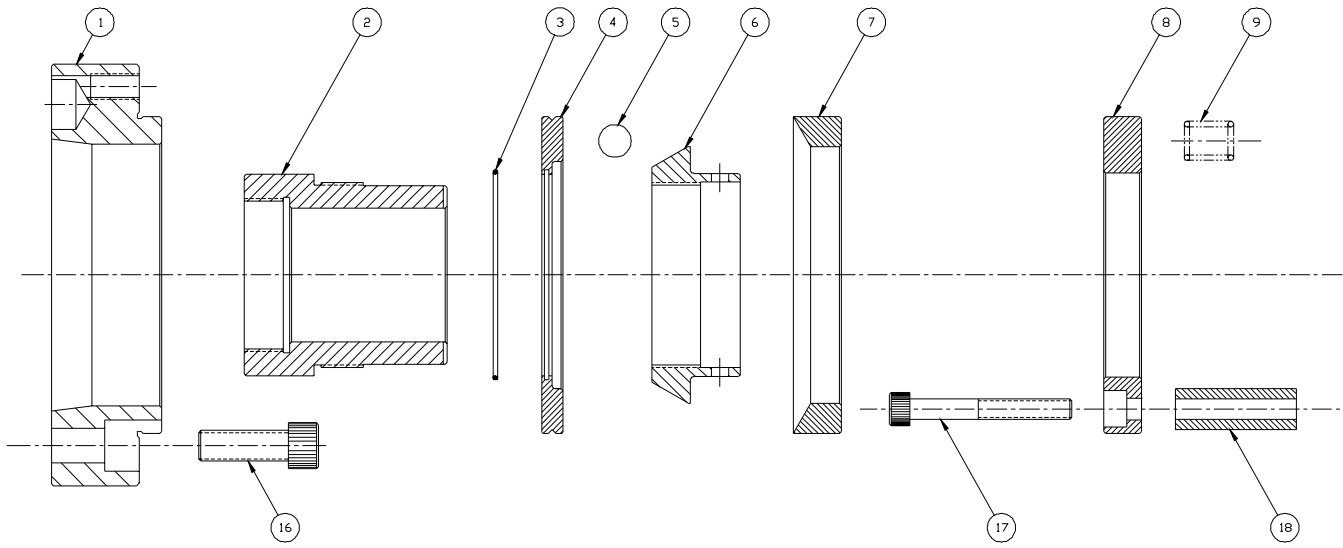

Item No.	Qty	Description
1	1	Spindle Adapter
2	1	Draw Tube Connector
3	1	O-Ring
4	1	Retaining Plate
5	23	Ball Bearing
6	1	Actuator
7	1	Tapered Ring
8	1	Bushing Ring
9	6	Spring
10	3	Locking Set Screw
11	1	Collet Chuck Body
12	6	Chuck Body Mounting Screw
13	1	Locating Key
14	1	Lock Screw
15	1	Collet - Quick Change or Master
16	6	Spindle Adapter Mounting Screw

Item No.	Qty	Description
17	3	Collet Sleeve Mounting Screw
18	3	Collet Sleeve Bushing
19	1	O-Ring
20	4	Radial Adjusting Screw
21	1	Face Seal
22	2	O-Ring
23	1	Tapered Collet Sleeve

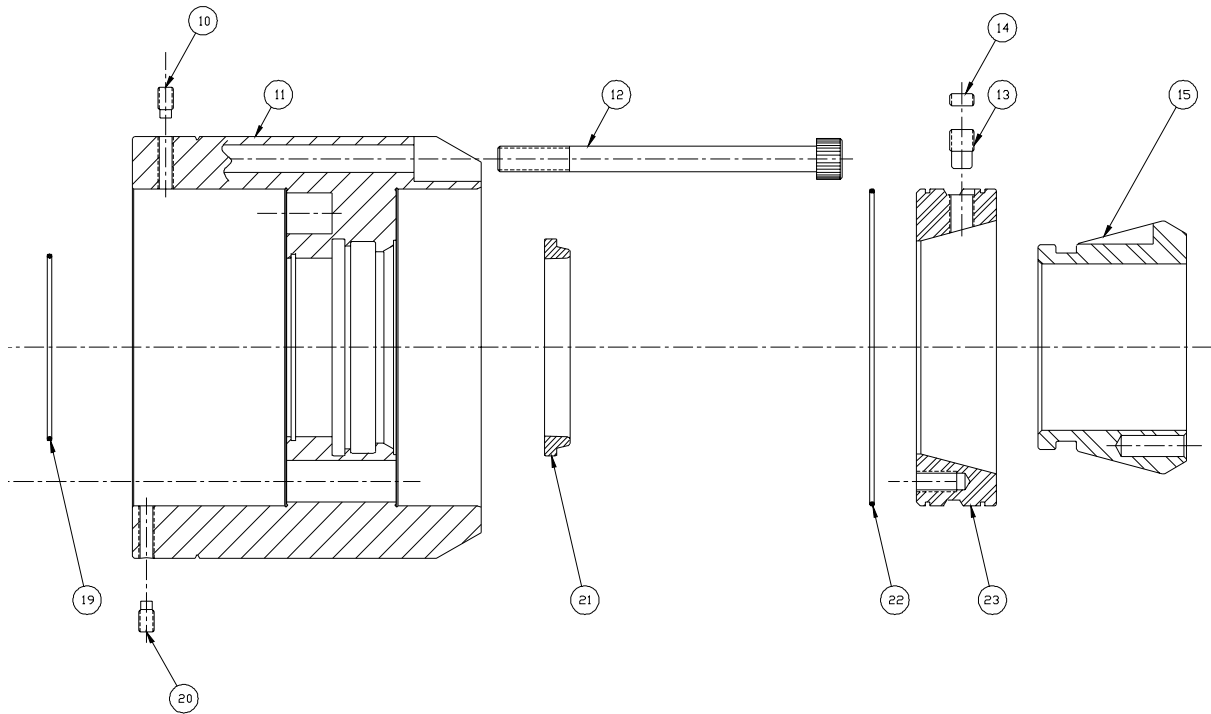

## 9.0 COLLET CHUCK INSTALLATION

MicroCentric collet chucks are supplied with a spindle mounting plate and a threaded draw tube connector to suit the machine configuration specified when the chuck was ordered. Refer to the chuck assembly drawings (on pages 13 and 14) to familiarize yourself with the chuck's components before installation.

### 9.1 MOUNTING ADAPTER PLATE

1. Make certain that the spindle and the mounting plate are clean and free of nick or burrs that could prevent the proper seating of the adapter plate.
2. Mount the adapter plate to the machine spindle. Tighten the mounting bolts to the recommended torque value given in section 4.0.
3. Use a dial indicator to measure the radial and face runout of the mounting surfaces of the adapter plate. Radial runout should not exceed .0002" (0.010mm). Runout of the face should not exceed .0001" (0.005mm). On flat spindle noses, the radial runout can be adjusted by loosening the mounting bolts and tapping the mounting plate with a plastic hammer. On tapered spindle noses no adjustment is possible. If the runout exceeds these values, remove the adapter from the spindle nose and verify that the adapter plate is seating properly and is clean and free of nicks and burrs. A skim cut can be taken on the pilot diameter and mounting face of the adapter once it is mounted to the spindle to assure that both surfaces are running true.

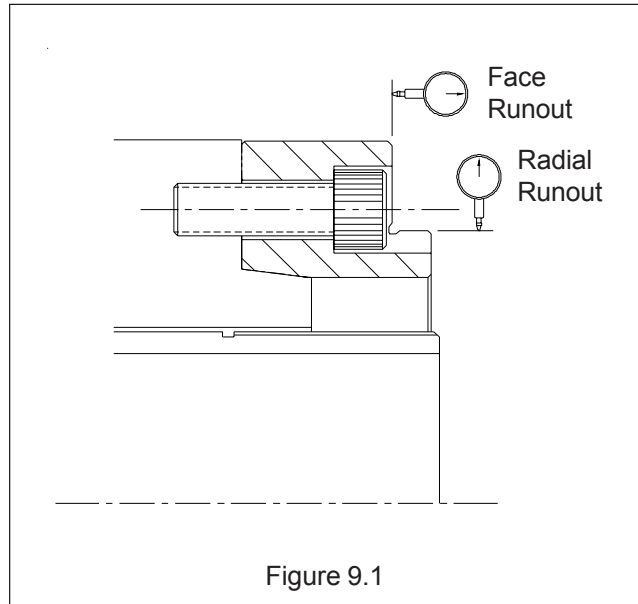

Figure 9.1

### IMPORTANT

**The radial runout of the mounting plate should not exceed .0002" (0.005mm), and the runout of the face of the mounting plate should not exceed .0001" (0.0025mm).**

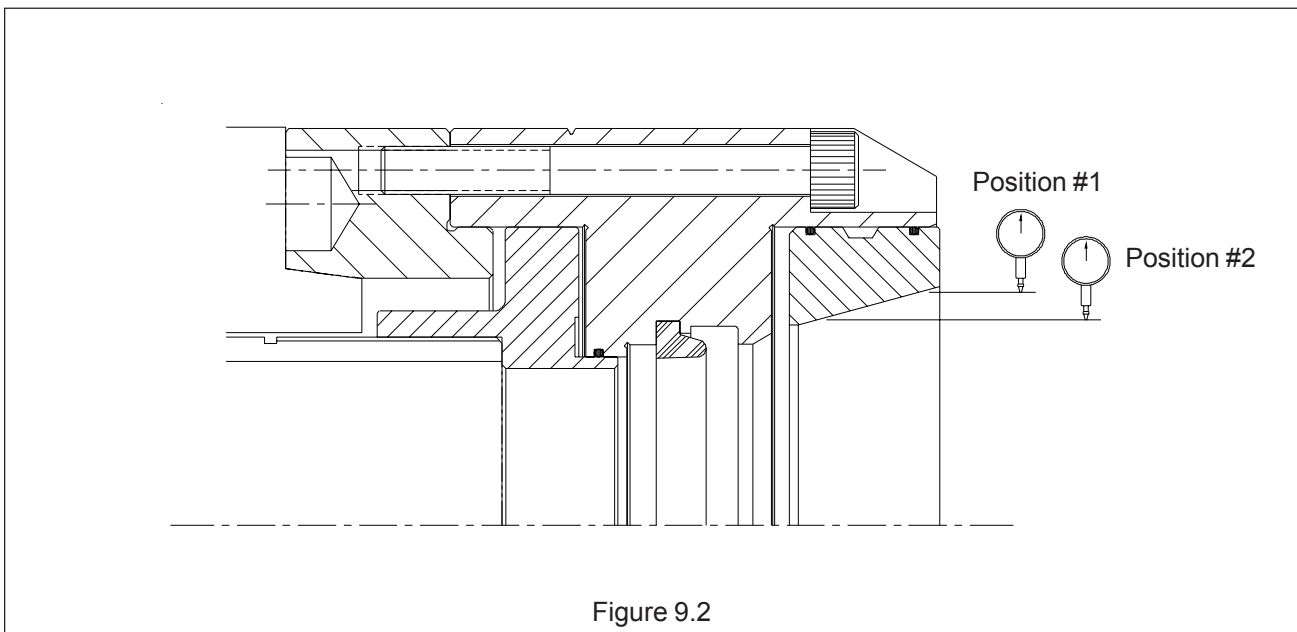

Figure 9.2

## 9.2 MOUNTING CHUCK ASSEMBLY

1. Set the draw tube force to the lowest pressure that is available for your machine. Actuate the draw tube to bring it to the forward position.
2. Remove the rubber face seal (item #21) from the groove in the ID of the chuck body.
3. Make certain that the mounting surfaces of the chuck body and adapter plate are clean and free of nicks or burrs that could prevent the proper seating of the chuck body. Also make sure the (4) radial adjusting screws (item #20) are not protruding into the locating diameter of the chuck body.
4. Using the special spanner wrench supplied with the chuck, thread the entire chuck assembly onto the draw tube until the thread bottoms out. Then back the chuck assembly off the draw tube thread 1/4 turn.
5. Actuate the draw tube to seat the chuck onto the adapter plate, and align the mounting bolts in the body with the mounting holes on the adapter plate.
6. Semi tighten all the mounting bolts, but do not fully tighten them at this point.
7. Indicate the ID runout of the collet taper as shown in position #1 in figure 9.2. Make adjustments to the (4) radial adjusting screws so that the runout of the collet taper is within .0001" (0.0025mm).
8. Before tightening the mounting bolts, measure the runout of the collet taper on position #2 in figure 9.2. If the chuck body is properly seated on the adapter plate, the runout measured on position #2 should be the same as position #1. If the runout measured in position #2 exceeds the runout of position #1 by more than .0001" (0.0025mm), remove the chuck body from the adapter plate and repeat this mounting procedure.
9. After the runout of the collet taper has been adjusted, tighten the mounting bolts to the torque specifications given on page 7. Also make sure to tighten all (4) radial adjusting screws.
10. Actuate the draw tube to verify that the chuck is functioning correctly by measuring the stroke of tapered sleeve as shown in figure 9.3.
11. Replace the face seal in the ID of the chuck body.

### IMPORTANT

**Verify that the chuck is functioning correctly by measuring the stroke of the collet sleeve.**

### IMPORTANT

**The runout of the ID of the tapered collet seat should not exceed .0002" (0.010mm).**



### CAUTION

**Do not unscrew the (3) locking set screws (item #10) on the OD of the chuck body. These screws secure the retaining plate (item #8), and should not be confused with the (4) radial adjusting screws (item #20).**

Chuck Model	Min.	Max.
CB65-NDR	-.070"	+.090"
	-1.8mm	+2.3mm
CB80-NDR	-.095"	+.065"
	-2.4mm-	+1.7mm

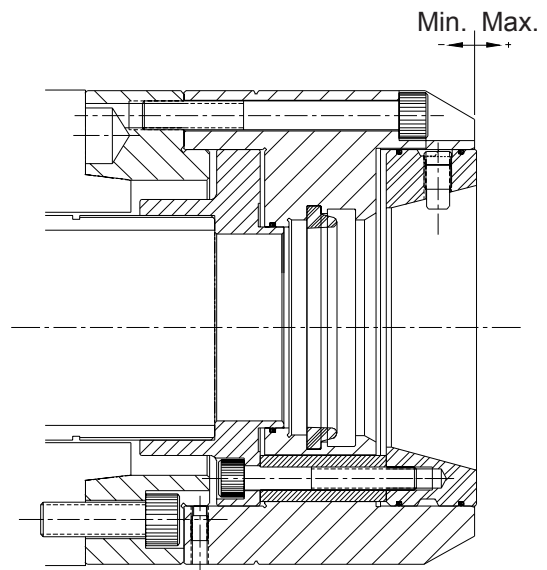

Figure 9.3

## 10.0 QUICK CHANGE COLLET INSTALLATION & CHANGEOVER

MicroCentric quick change collets are collapsed by a changing fixture for installation and removal from the collet chuck. Changing fixtures are available in manual and pneumatic models.

### 10.1 COLLET INSTALLATION

1. Insert the pins on the changing fixture into the holes on the face of the quick change collet.
2. Actuate the changing fixture to collapse the collet. On manual changing fixtures turn the hand wheel clockwise until the rear of all collet segment are touching. On pneumatic changing fixtures depress and hold the trigger button.
3. With the collet fully collapsed, insert the collet into the tapered collet seat. Make certain that the key slot in one of the collet segments is aligned with the key in the tapered collet seat.
4. While pressing the rear of the collet firmly against the face seal inside the chuck body, release the collet by turning the hand wheel counterclockwise on the manual changing fixture. On pneumatic changing fixtures, release the trigger button.
5. Remove the changing fixture from the collet.
6. Actuate the chuck to make sure the collet is properly coupled in the chuck body. Also clamp a plug, bar end, or workpiece in the collet to verify the collet is clamping properly.

### 10.2 COLLET REMOVAL

1. Insert the pins on the changing fixture into the holes on the face of the quick change collet.
2. Actuate the changing fixture to collapse the collet.
3. When the collet is fully collapsed pull the collet straight out from the chuck.
4. After the collet has been removed from the chuck, remove the collet from the changing fixture by releasing the changing fixture.

#### IMPORTANT

**The collet chuck must be in the unclamped position when installing and removing quick change collets. Dead length chucks are unclamped when the collet sleeve is fully retracted.**

#### IMPORTANT

**Verify the collet is properly coupled into the chuck body by actuating the chuck before attempting to clamp a workpiece.**



#### CAUTION

**Do not continue to turn the hand wheel on the manual changing fixtures after all collet segments are touching.**



#### CAUTION

**Do not exceed 100 psi inlet air pressure for pneumatic changing fixtures.**

#### IMPORTANT

**If the collet does not easily go into or come out of the coupling inside the collet chuck body, check to make sure the collet is fully collapsed. Check to make sure that chips are not preventing the collet from collapsing. Also make sure the collet chuck is in the unclamped position.**

## 11.0 "S" PAD MASTER COLLET INSTALLATION & REMOVAL

MicroCentric "S" pad master collets are a bayonet coupling design. A collet installation ring is used to install and remove the master collet from the chuck.

### 11.1 COLLET INSTALLATION

1. Back out all collet keys from the ID of the tapered collet seat, by turning the collet keys counter-clockwise with a hex wrench. Make sure each key is below the tapered surface of the collet seat.
2. Verify that the face seal is properly seated in the groove behind the collet coupling. It is recommended that grease be applied to the face seal to make sure the master collet turns smoothly as it is installed in the chuck.
3. Place the master collet into the tapered seat of collet chuck. Make sure the ears on the coupling on the collet engage into the cutouts in the coupling in the chuck body.
4. Place the collet installation ring onto the face of the collet. The pins on the bottom face of the ring should engage into the rubberized slots on the master collet.
5. Press the master collet firmly against the face seal in the chuck body and turn the installation ring until the alignment mark is in line with one of the collet keys.
6. Bring one collet key back into the collet seat by turning it clockwise with a hex wrench, and engage the key into the key slot on the OD of the master collet. You may need to turn the master collet slightly to allow the key to engage in the slot.
7. Engage the other collet keys in the slots on the OD of the master collet. Make sure each key is tight, and each retaining screw is replaced on the OD of the chuck body.
8. Actuated the chuck to make sure the master collet is properly coupled into the collet chuck body.

### 11.2 REMOVING THE MASTER COLLET

1. Back out the collet keys to disengage them from the key slots on the OD of the master collet.
2. Insert the installation ring onto the face of the master collet and turn the collet until the coupling is released. Turn the collet 60 degrees on CB46 and CB65 model chucks, and 90 degrees on CB80 models.
3. Remove the master collet from the tapered collet seat in the chuck body by pulling is straight out from seat.

#### IMPORTANT

**The collet chuck must be in the unclamped position when installing and removing the master collet. Dead length chucks are unclamped when the collet sleeve is fully retracted.**

#### IMPORTANT

**Remove the collet pads from the master collet before installing or removing the master collet from the chuck.**

#### IMPORTANT

**Make sure all collet keys are properly engaged in the key slots on the OD of the master collet after installation.**

#### IMPORTANT

**Verify the master collet is properly coupled into the chuck body by actuating the chuck before attempting to clamp a workpiece.**

## 12.0 CHANGING FIXTURE ASSEMBLY DRAWINGS & PARTS LISTS

### 12.1 MANUAL COLLET CHANGING FIXTURE

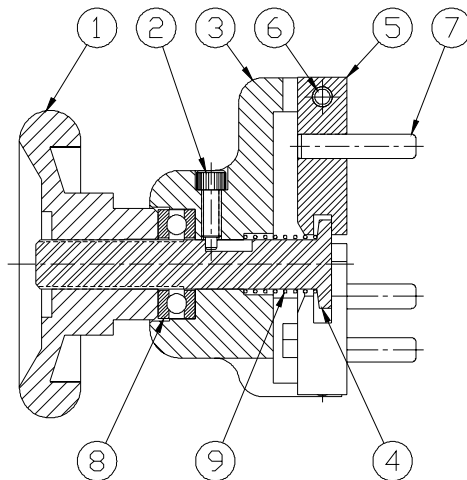

Item No.	Qty	Description
1	1	Hand Wheel
2	1	Retaining Screw
3	1	Housing
4	1	Rod Actuator
5	3	Jaw
6	3	Pivot Pin
7	3	Collet Pin
8	1	Bearing
9	1	Spring

## 12.2 PNEUMATIC COLLET CHANGING FIXTURE

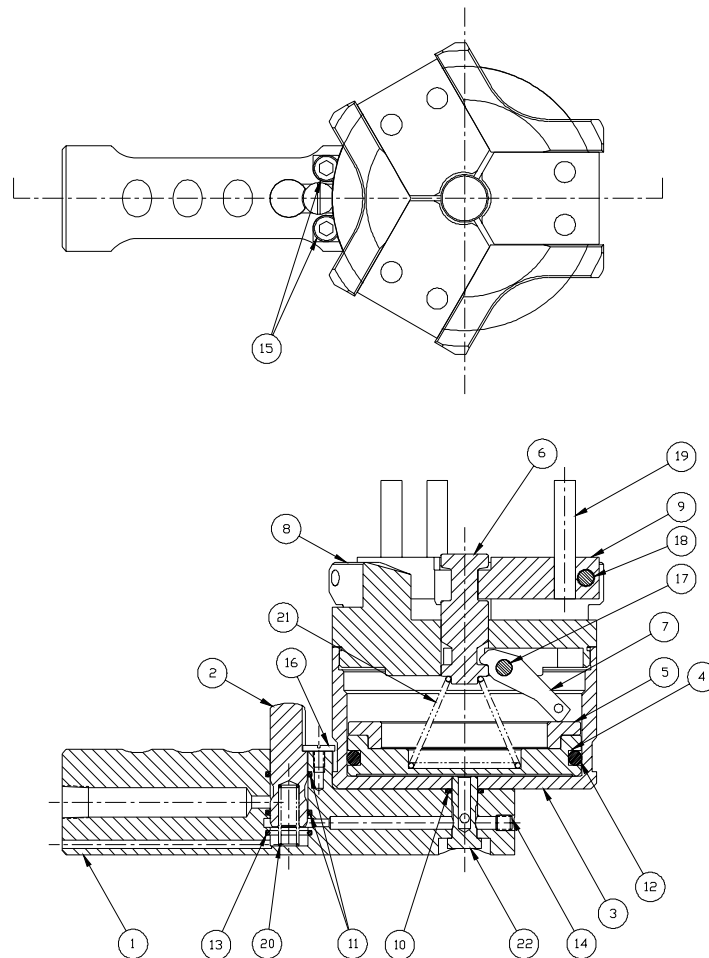

Item No.	Qty	Description
1	1	Handle
2	1	Trigger
3	1	Cylinder
4	1	Piston
5	1	Wear Plate
6	1	Actuator Rod
7	3	Lever*
8	1	Front Plate
9	3	Jaw*
10	1	O-Ring
11	2	O-Ring

Item No.	Qty	Description
12	1	O-Ring
13	1	O-Ring
14	1	Set Screw
15	2	Socket Head Cap Screw
16	1	Retaining Screw
17	3	Lever Pivot Pin
18	3	Jaw Pivot Pin
19	6	Collet Pin
20	1	Trigger Spring
21	1	Conical Spring
22	1	Hollow Bolt

## 13.0 TROUBLE SHOOTING GUIDE

This trouble shooting guide is intended to help you identify some common causes of problems experienced operating MicroCentric collet chucks, or correctly clamping a bar or workpiece. For further assistance contact one of our technical sales associates.

PROBLEM	POSSIBLE CAUSE	SUGGESTED REMEDY
<b>The tapered collet sleeve does not stroke fully.</b>	The forward and retracted position of the draw tube was not specified correctly.	Refer to the spindle data sheet on page 22. Remove the collet chuck from the machine spindle and measure the draw tube position.
	The threaded draw tube connector was not made correctly.	Compare the design of the draw tube connector with the spindle data sheet for the machine model the chuck is being mounted to.
	Chips and sludge mat have accumulated inside the chuck body preventing the collet sleeve and/or the draw tube connector from stroking fully.	Disassemble the chuck and clean all chips and sludge that has built up inside the chuck body.
<b>Workpiece (bar) runs out excessively.</b>	Tapered collet seat is running out, (mounting screws not tight).	Indicate ID of the collet seat and retrue chuck to within specifications given in section 9.2. Make sure all mounting screws are tight.
	Chips, dirt, or other foreign material has accumulated between the collet and tapered collet seat.	Remove the collet and clean out all accumulated chips and sludge from inside the chuck, both from tapered seat and coupling area.
	The tapered collet seat in the chuck body is worn.	Replace the chuck body assembly or regrind the ID of the tapered collet seat.
	The clamping diameter and/or the OD taper of the collet have worn.	Replace or regrind the collet. Note only the clamping diameter of a collet can be reground.
<b>Workpiece (bar) slips or pushes back during machining.</b>	Collet is oversized for the bar or workpiece clamping diameter.	Use a collet with a clamping diameter that matches the OD of the bar or workpiece.
	Insufficient clamping force.	Increase the hydraulic pressure to the cylinder to increase the draw tube force to the chuck.
	Cutting force is too high.	Reduce cutting force.
	Coefficient of friction between collet and workpiece (bar) is insufficient.	Use a serrated collet. Use more aggressive serrations. Or apply a diamond particle plating or carbide grit to the clamping surface of the collet.
	Spindle speed is too high.	Reduce spindle speed.
<b>Workpiece comes out of the collet, or collet uncouples from the chuck when clamping.</b>	A workpiece whose overall length is shorter than .312" (8mm) is being clamped.	Use a reduced nose collet for clamping short workpieces. Refer to section 5.3 on page 9 regarding the clamping of short workpieces.
	Too short a length of the workpiece is being clamped.	If using a standard nose collet, increase the length being clamped to .37" (10mm) minimum.
<b>Pneumatic collet changing fixture does not actuate.</b>	The air passage in the trigger button is clogged from using unfiltered air.	Remove the trigger button from the handle assembly and clear the clog in the air passage.

## 14.0 SPINDLE DATA SHEET

Chuck Model		Date	
Serial No.		Ref. No.	

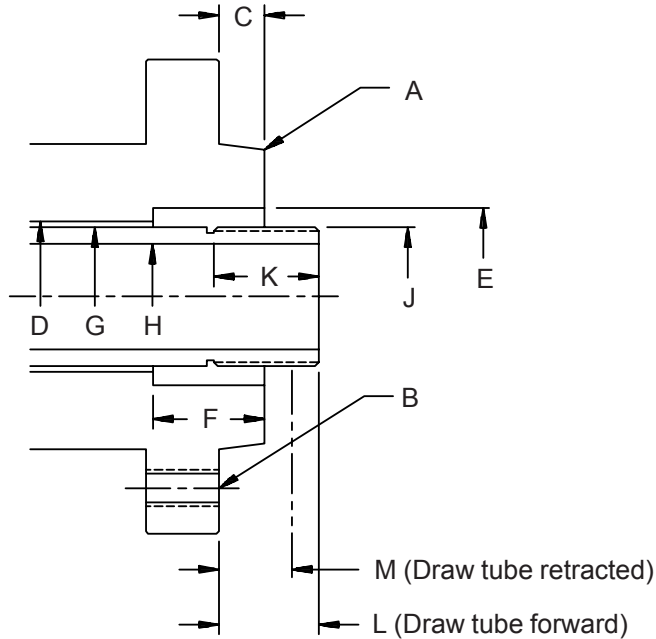

Machine Make	
Machine Model	
Machine Serial No.	
A* taper size	
B mounting thread	
C length of pilot	
D through hole diameter	
E ID counterbore or taper (if any)	
F depth of counterbore (if any)	
G OD of draw tube	
H ID of draw tube	
J thread (RH or LH / ID or OD)	
K length of thread	
L** forward position	
M retracted position	

\* For machines with a straight spindle pilot a detail drawing of the spindle must be submitted

\*\* Positive (+) indicates draw tube is in front of the spindle face (as shown)  
 Negative (-) indicates draw tube is behind the spindle face



MicroCentric Corp • 25 Terminal Drive, Plainview, NY 11803 • USA  
Tel: 516-349-7220 • Fax: 516-349-9354 • e-mail: [sales@microcentric.com](mailto:sales@microcentric.com)

***1-800-573-1139***

***[www.microcentric.com](http://www.microcentric.com)***