



Installation & Operating Manual for LDZ High Speed Air Cylinders



www.MicroCentric.com

TABLE OF CONTENTS

1.0 Contact & Service Information	1
2.0 Introduction	2
3.0 Precautions for Safe Operation	3
4.0 Specifications	4
5.0 Assembly Drawing & Parts List	4
6.0 Installation Diagram	5
7.0 Air Supply & Lubrication	5
8.0 Mounting Procedure	6

1.0 CONTACT & SERVICE INFORMATION

Manufactured by:	MicroCentric Corp. Plainview, NY USA
Service in North America:	MicroCentric Corp. 25 Terminal Drive Plainview, NY 11803 USA Tel: 1-800-573-1139 & 1-516-349-7220 Fax: 1-516-349-9354 E-mail: service@microcentric.com
Service in Europe:	MicroCentric GmbH Auf der Hub 9 D-70439 Stuttgart Germany Tel: 49-711-9809240 Fax: 49-711-802483 E-mail: info@microcentric.de
Service in Asia:	Dynamic Tools Corp. 3-3-13 Saikujo-cho Nara 630 Japan Tel: 81-742-62-6760 Fax: 81-742-62-6766 E-mail: dynex@earth.email.ne.jp

2.0 INTRODUCTION

MicroCentric LDZ Series High Speed Air Cylinders are produced to the highest standards of precision and accuracy. LDZ Air Cylinders are an advanced design which feature a precision rotary air bearing. If this unit is correctly installed and properly maintained, it will provide years of trouble-free operation and performance.

The information in this manual, if followed, will enable you to obtain maximum performance and life from MicroCentric air collet closers and collet noses. Please keep this manual handy for easy reference.



Safety Alert Symbol

This is the industry "Safety Alert Symbol". This symbol is used to call your attention to items or operations that could be dangerous to you or persons using this equipment. Please read these messages and follow these instructions carefully. It is essential that you read the instructions and safety regulations before you attempt to assemble or use this unit.



DANGER

Indicates an imminent hazardous condition which, if not avoided, could result in serious injury or death.



WARNING

Indicates a potentially hazardous condition which, if not avoided, could result in serious injury or death.



CAUTION

Indicates a potentially hazardous condition which, if not avoided, could result in minor or moderate injury.

IMPORTANT

Instructions for optimum performance and avoiding errors or misuse of the chuck or cylinder.

3.0 PRECAUTIONS FOR SAFE OPERATION

 WARNING	
Do not run the air cylinder without supplying air pressure to the rotary air bearing assembly.	The rotary air bearing will run hot, which over a period of time can damage the ball bearings and lead to potential seizure of the assembly.

 DANGER	
Always supply dry, clean (filtered), and lubricated air to actuate the air cylinder.	Supplying clean, lubricated air to the collet closer prevents contamination of the rotary air bearing which could lead to seizure of the assembly.

 WARNING	
Do not run the air cylinder without supplying lubrication to the rotary air bearing assembly.	A continuous oil mist must be supplied to the rotary air bearing assembly. Failure to do so will shorten the life of the ball bearings.

 CAUTION	
When the machine has been sitting for a period of time (especially overnight), run the spindle at 100 rpm for 5 minutes.	Running the air cylinder at high speeds when the unit is cold can damage the rotary air bearing assembly.

4.0 SPECIFICATIONS

Model No.	LDZ-150	LDZ-200	LDZ-250
Through Hole	1.355" (34.4mm)	1.355" (34.4mm)	1.355" (34.4mm)
Piston Stroke	0.394" (10mm)	0.710" (18mm)	.710" (18mm)
Maximum Air Pressure	150 psi (10.5 kg/cm ²)	150 psi (10.5 kg/cm ²)	150 psi (10.5 kg/cm ²)
Draw Tube Force @ 100psi	1640 lbs (745 kg)	2,920 lbs (1,327 kg)	5,200 lb (2,364 kg)
Maximum Speed	6,000 rpm	6,000 rpm	4,000 rpm

5.0 ASSEMBLY DRAWING & PARTS LIST

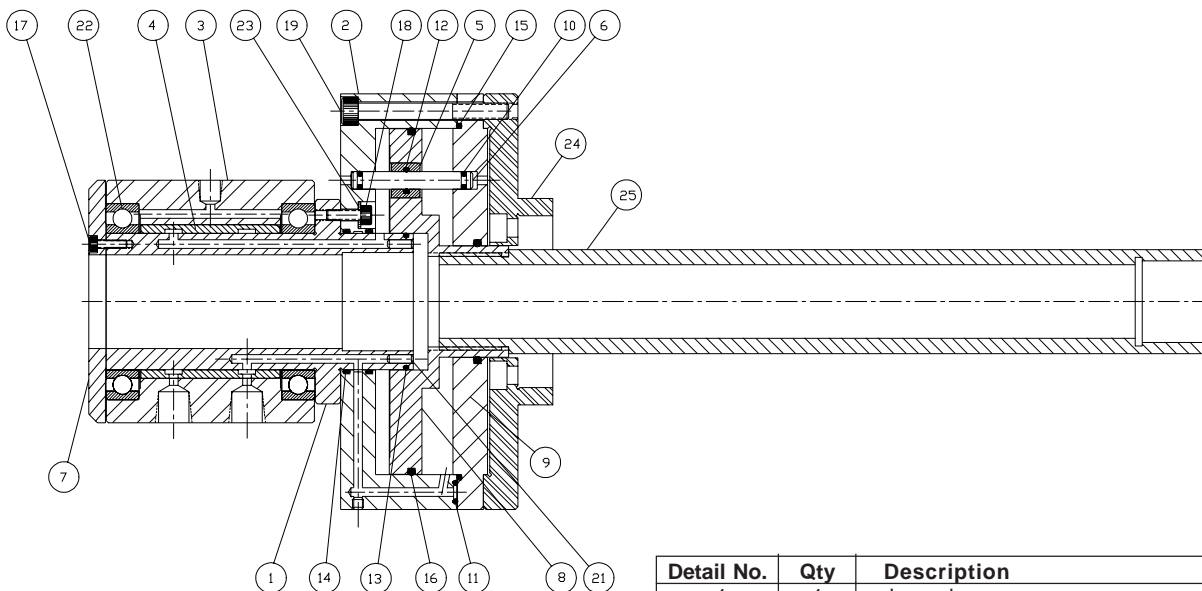

Detail No.	Qty	Description
1	1	Journal
2	1	Cylinder
3	1	Air Bearing Housing
4	1	Oil-Lite Sleeve
5	2	Bushing
6	2	Pin
7	1	EndCap
8	1	Piston
9	1	Back Cover
10	4	O-Ring 2-006 Buna
11	2	O-Ring 2-008 Buna
12	2	O-Ring 2-010 Buna
13	2	O-Ring 2-031 Buna
14	2	O-Ring 2-033 Buna
15	1	O-Ring 2-049 Buna
16	1	O-Ring 2-158 Buna
17	3	M3 x 12 Soc Hd Cap Screw
18	4	M4 x 12 Soc Hd Cap Screw
19	6	M6 x 45 Soc Hd Cap Screw
21	6	Brass Sealing Plug
22	2	Bearing 61910
23	4	Sealing Washer
24	1	Spindle Adapter (as required)
25	1	Draw Tube (as required)

6.0 INSTALLATION DIAGRAM OF AIR CYLINDER

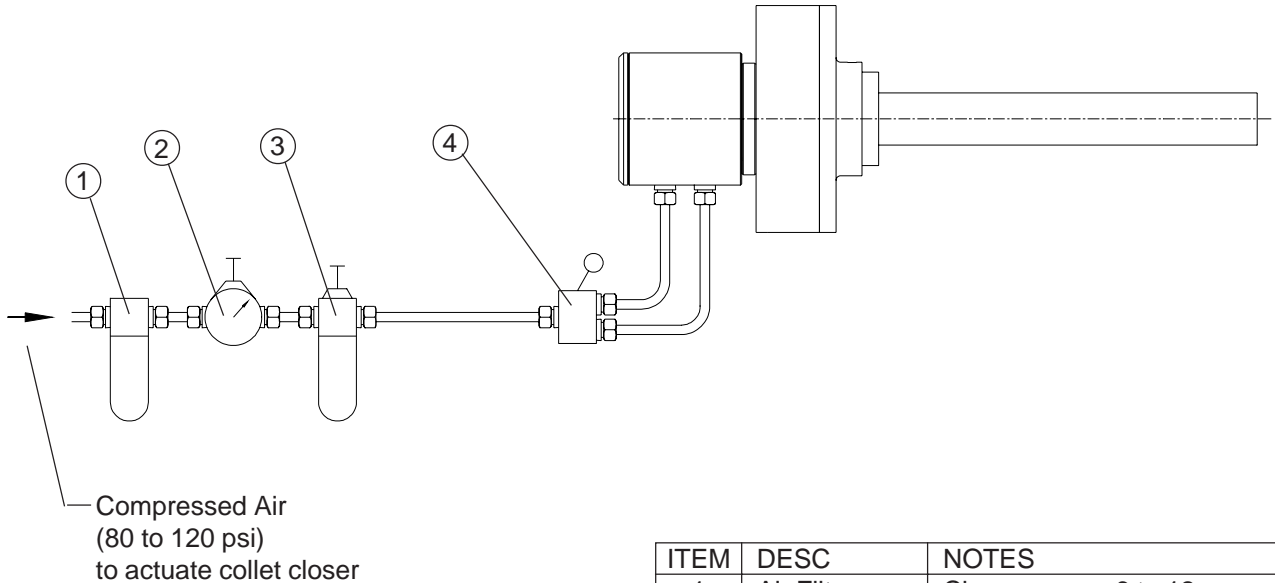

ITEM	DESC	NOTES
1	Air Filter	Change every 6 to 12 mo.
2	Pressure Regulator	Max. 100 psi (7 kg/cm ²) Min. 20 psi (1.5 kg/cm ²)
3	Lubricator	1 drop every 60 sec.
4	Valve	Manual or electric solenoid

7.0 AIR SUPPLY & LUBRICATION

LDZ Air Cylinders will provide many hours of continuous, trouble free operation if the unit is properly installed and the following precautions are observed:

1. The air that is supplied to actuate the collet closer must be lubricated and filtered.
2. Always run the collet closer with air pressure to the rotary air bearing assembly. Air flow is required for the proper function of the air bearing, and will also dissipate any heat generated during operation.
3. Set the lubricator unit to deliver 1 drop of oil every 60 seconds.
5. Always make sure that the lubricator unit is filled with oil. The oil level should be checked regularly.
6. Change the filter element in the air filter unit at least every 6 months.

RECOMMENDED LUBRICANT

Mobil Velocite No. 6 or equivalent



WARNING

Always supply filtered & lubricated air to the collet closer.



DANGER

Never run the collet closer without air pressure supplied to the unit.



DANGER

Never operate or run the collet closer when the oil reservoir in the lubricator unit is low or empty.

8.0 MOUNTING PROCEDURE

MicroCentric LDZ Air Cylinders usually require an adapter plate to mount to the rear of the machine spindle. Refer to the assembly drawing in section 5.0 to familiarize yourself with the unit's components.

1. First mount the adapter plate to the rear of the machine spindle. Clean all surfaces of both the spindle and mounting plate. Make sure surfaces are free of dirt, nicks, and burrs that would prevent the proper seating of the adapter plate. Tighten the mounting screws alternately and equally to the recommended torque for the screw size used. *Do not over-tighten.*
2. Use a dial indicator to check the runout of the mounting face and pilot diameter of the adapter plate. The runout of the pilot diameter should be within .0004" (0.010 mm). The runout of the mounting face must be within .0002" (0.050 mm).
3. Thread the draw tube into air cylinder. Use a strap wrench to tighten the draw tube. A removable thread locking compound may be used to make sure the thread does not loosen during operation. *Never use a permanent thread locking compound.*
4. Mount the air cylinder to the adapter plate. Make sure all surfaces are free of chips, dirt, nicks, and burrs that could prevent the proper seating. Do not tighten the (6) mounting screws fully at this time.
5. Measure the runout of the OD of the air bearing housing in the middle with a dial indicator. Adjust the runout to within .0008" (0.020 mm).
6. Tighten the (6) mounting screws alternately and equally to the recommended torque for the screw size used. *Do not over-tighten.*
7. Check the runout of the air bearing housing again to verify it has not changed as the mounting screws were tightened.
7. Mount an anti rotation bracket to the machine, and insert an M6 screw through the bracket and thread it into the tapped hole on the OD of the housing. The anti rotation screw should not exert side load or drag which would prevent the free rotation of the air bearing assembly.
8. Referring to the installation diagram in section 7.0, connect the 2 air lines which actuate the collet closer into the 1/4"-27 NPT fittings on the rotary air bearing. The inner port (closest to the cylinder) is for clamping; the outer port (at the rear) is for unclamping.



CAUTION

Do not apply excessive torque to the mounting screws when mounting the adapter plate or air cylinder.



CAUTION

The radial runout of the sleeve should not exceed .0008" (0.020mm) TIR.



WARNING

The air and lubrication fittings are installed at the factory and should never be overtightened as the air bearing housing can be distorted.



WARNING

The anti rotation screw can not exert side load or drag on the air bearing housing. Minimum clearance .020" (0.5mm) per side.

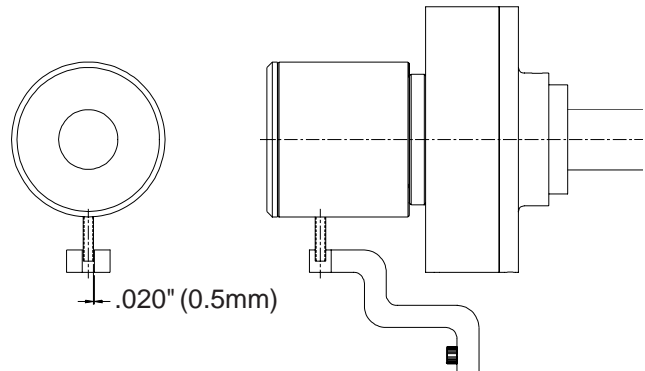



MicroCentric Corp • 25 So. Terminal Drive, Plainview, NY 11803 • USA
Tel: 516-349-7220 • Fax: 516-349-9354 • e-mail: sales@microcentric.com

1-800-573-1139

www.MicroCentric.com