

Collet Chucks for "S" Style Collet Pads



Table of Contents

Overview & Product Features	2
Description of Chuck Models	3
CB-NB/S Collet Chucks - <i>Pull Back</i> Design	4
CB-ND/S Collet Chucks - <i>Dead Length</i> Design	6
CB-ND/NDR/S Collet Chucks - <i>Pull to Close Dead Length</i> Design	8
CB-NS/S Collet Chucks - <i>Sub Spindle</i> Design	10
Master Collets	12
Collet Installation Fixtures	12
Ejectors for Sub Spindle Collet Chucks	12
Spindle & Draw Tube Data Sheet	13

Commitment to Service

MicroCentric Master Collet Chucks are available from stock and can be adapted to any machine configuration. MicroCentric is not only committed to building the world's finest workholding products, but we also strive to provide our customers with unmatched service and support.



"S" Pad Collet Chuck Overview

MicroCentric introduces a new line of Collet Chucks for "S" Style Collet Pads. The MicroCentric design is based on a vulcanized master collet which allows the chuck to be shorter than designs using conventional spring type master collets. Shorter chuck length promotes increased rigidity and enables full use of a machine's Z axis. The MicroCentric master collet also produces a parallel clamping action that results in higher chucking forces. This feature together with greater rigidity permits heavier cuts and improves tool life.

High Clamping Force

- Parallel clamping design generates higher clamping forces than traditional collet and three jaw chucks

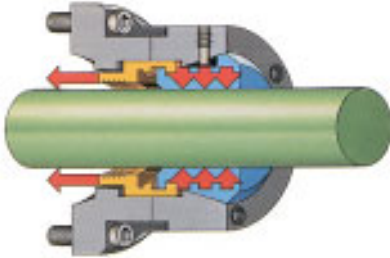

Low Profile Design

- Short overall length for maximum Z axis utilization
- Reduced OD for increased tool clearance

High Spindle Speeds

- Up to 6,000 rpm

Large Clamping Range

- +/- .020" (0.5 mm) range to accommodate variations in bar stock diameter

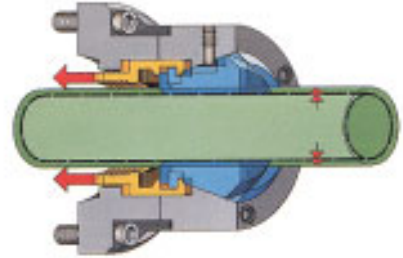

Superior Rigidity

- Shorter overall chuck length
- Workpiece is machined closer to spindle face
- High chuck rigidity improves cutting tool life and allows higher metal removal rates for shorter cycle times

Up to 35% greater rigidity

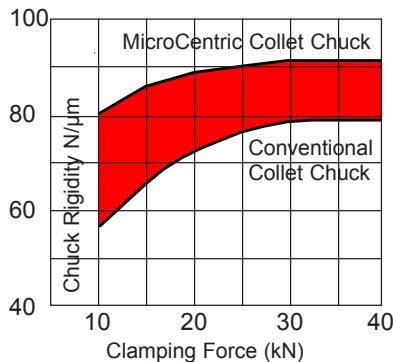

50% higher clamping force

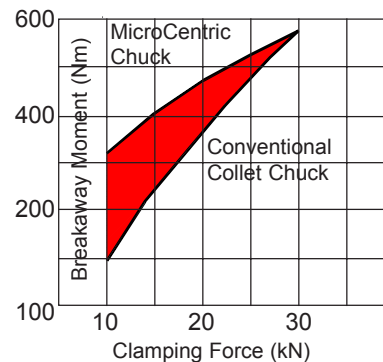

Vulcanized Master Collet

MicroCentric has manufactured a vulcanized Quick Change Collet System for over 15 years, and utilizes this technology to bring you a new series of Master Collet Chucks of unmatched design, performance, and features. The vulcanized rubber is specially formulated to be resistant to coolants and cutting oils. The bond between rubber and metal is permanent and is guaranteed for the life of the collet.

"S" Pad Collet Chuck Models

All components of MicroCentric Collet Chucks are made from hardened and precision ground alloy steel for high accuracy and unsurpassed long term performance. Their modular design makes it possible to adapt MicroCentric chucks to all machine spindle nose and draw tube configurations.

NB/S Series - *Pull Back Design*

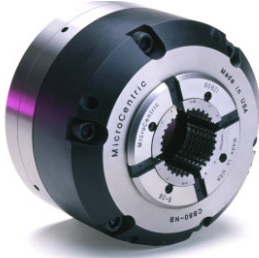

In the CB-NB/S series collet chuck, the master collet is coupled directly into the draw tube connector. As the draw tube is actuated, the master collet is drawn into the tapered seat of the chuck body, efficiently translating draw tube force into maximum clamping force.

ND/S Series - *Dead Length Design*



ND/S models are ideal for bar applications feeding out to a turret mounted stop. The master collet is coupled directly into the chuck body and remains stationary as the tapered seat moves forward when the chuck is actuated. This design keeps the collet in a fixed Z axis position during clamping and imparts no pull back onto the bar stock.

NDR/S Series - *Pull to Close Dead Length Design*



The CB-NDR/S series collet chuck, is a new patented *Dead Length* design for use with servo stop bar loaders. The chuck is actuated as the draw tube is pulled into machine spindle. The master collet is coupled to the chuck body and remains stationary as the tapered seat moves forward during clamping. This keeps the collet in a fixed Z axis position, and since the draw tube is moving into the spindle, the bar remains against the servo stop.

NS/S Series - *Dead Length Design for Sub Spindles*



NS/S models are a reduced diameter *Dead Length* design for sub spindle applications. Similar to the ND/S chucks, the master collet is coupled directly into the chuck body and remains stationary as the tapered seat moves forward when the chuck is actuated. The NS/S chuck also features a provision inside the chuck body for mounting ejectors or stops.

CB-NB/S Collet Chucks - Pull Back Design

In the CB-NB/S series collet chuck, the master collet is coupled directly to the draw tube connector. As the draw tube is actuated, the master collet is drawn into the tapered seat of the chuck body, efficiently translating draw tube force into maximum clamping force.

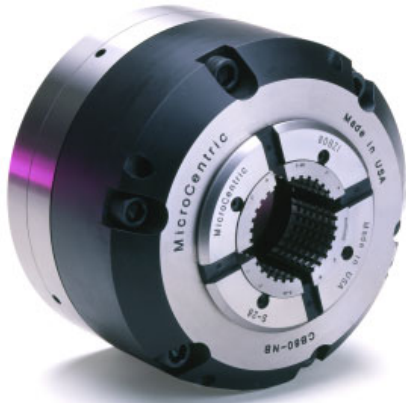

CB-NB/S Features

- Pull Back design maximizes the efficiency of the clamping system by concentrating all forces in the direction of the spindle for highest accuracy and greatest overall rigidity
- Low profile OD and short overall length provides increased tool clearance and maximum utilization of the machine's Z axis travel compared to conventional master collet chucks
- Radial adjusting screws for fast, accurate adjustment
- Lubricated-for-life design requires minimal maintenance
- All components hardened and precision ground for highest accuracy and long life
- Vulcanized master collet and rubber face seal inside chuck body eliminates chip and coolant contamination
- Spindle speeds up to 6,000 rpm

CB-NB/S Specifications

Chuck Model	CB46-NB/S16	CB65-NB/S20	CB65-NB/S22	CB80-NB/S26	CB80-NB/S30	CB100-NB/S35
Master Collet Model	S-16	S-20	S-22	S-26	S-30	S-35
Through Capacity	1.625" 41.3mm	2.000" 50.8mm	2.250" 57.2mm	2.625" 66.7mm	3.000" 76.2mm	3.500" 88.9mm
Clamping Range	+/- .020" +/- 0.5mm	+/- .020" +/- 0.5mm	+/- .020" +/- 0.5mm	+/- .020" +/- 0.5mm	+/- .020" +/- 0.5mm	+/- .040" +/- 1mm
Draw Tube Stroke	.160" 4mm	.160" 4mm	.160" 4mm	.160" 4mm	.160" 4mm	.275" 7mm
Max. Draw Bar Force	7,850 lbs 3,580 kg	10,095 lbs 4,590 kg	10,095 lbs 4,590 kg	11,980 lbs 5,450 kg	11,980 lbs 5,450 kg	14,580 lbs 6,630 kg
Max. Clamping Force	14,130 lbs 6,425 kg	18,170 lbs 8,260 kg	18,170 lbs 8,260 kg	21,560 lbs 9,820 kg	21,560 lbs 9,820 kg	26,240 lbs 11,930 kg
Max Speed	6,000 rpm	6,000 rpm	6,000 rpm	5,000 rpm	5,000 rpm	4,500 rpm
Net Weight	16.7 lbs 7.6 kg	23.9 lbs 10.9 kg	23.9 lbs 10.9 kg	35.1 lb 15.9 kg	35.1 lb 15.9 kg	47.9 lbs 21.8 kg

Standard Equipment

CB-NB/S collet chucks are supplied with a vulcanized master collet, spindle adapter plate, blank draw tube connector, mounting screws and collet installation fixture. Threaded draw tube connectors for specific machine configurations are furnished at no additional charge if draw tube dimensions are provided with your purchase order. See page 13 for spindle and draw tube data sheet.

CB-NB/S Dimensions

Chuck Model	Fig.	Spindle Nose	Spindle							
			A	B	C	D	E	F	G	H
CB46-NB/140/S16	1	140mm	3.095"	4.250"	5.700"	-	-	2.050"	4.050"	.054"
			78.6mm	108mm	144.8mm	-	-	52.1mm	102.9mm	1.4mm
CB46-NB/A5/S16	1	A2-5	3.095"	4.250"	5.700"	-	-	2.450"	4.450"	.054"
			78.6mm	108mm	144.8mm	-	-	62.2mm	113mm	1.4mm
CB65-NB/A5/S20	1	A2-5	3.886"	5.000"	6.480"	-	-	2.800"	4.300"	.354"
			98.7mm	127mm	164.6mm	-	-	71.1mm	109.2mm	9mm
CB65-NB/A6/S20	1	A2-6	3.886"	5.000"	6.480"	-	-	3.350"	4.850"	.354"
			98.7mm	127mm	164.6mm	-	-	85.1mm	123.2mm	9mm
CB65-NB/A5/S22	1	A2-5	3.886"	5.000"	6.480"	-	-	2.800"	4.300"	.354"
			98.7mm	127mm	164.6mm	-	-	71.1mm	109.2mm	9mm
CB65-NB/A6/S22	1	A2-6	3.886"	5.000"	6.480"	-	-	3.350"	4.850"	.354"
			98.7mm	127mm	164.6mm	-	-	85.1mm	123.2mm	9mm
CB80-NB/A6/S26	1	A2-6	4.500"	5.875"	7.700"	-	-	2.955"	4.955"	.180"
			114.3mm	149.2mm	195.6mm	-	-	75.1mm	125.9mm	4.6mm
CB80-NB/A8/S26	2	A2-8	4.500"	5.875"	7.700"	9.200"	1.105"	3.210"	5.210"	.180"
			114.3mm	149.2mm	195.6mm	233.7mm	28.1mm	81.5mm	132.3mm	4.6mm
CB80-NB/A6/S30	1	A2-6	4.500"	5.875"	7.700"	-	-	2.955"	4.955"	.180"
			114.3mm	149.2mm	195.6mm	-	-	75.1mm	125.9mm	4.6mm
CB80-NB/A8/S30	2	A2-8	4.500"	5.875"	7.700"	9.200"	1.105"	3.210"	5.210"	.180"
			114.3mm	149.2mm	195.6mm	233.7mm	28.1mm	81.5mm	32.3mm	4.6mm
CB100-NB/A8/S35	1	A2-8	5.704"	7.000"	9.350"	-	-	3.410"	4.810"	.040"
			144.8mm	177.8mm	237.5mm	-	-	86.6mm	122.2mm	1mm
CB100-NB/A11/S35	2	A2-11	5.704"	7.000"	9.350"	10.950"	2.000"	4.250"	5.650"	.040"
			144.8mm	177.8mm	237.5mm	278.1mm	50.8mm	107.9mm	143.5mm	1mm

Spindle adapter plates other than those listed above are quoted upon request.

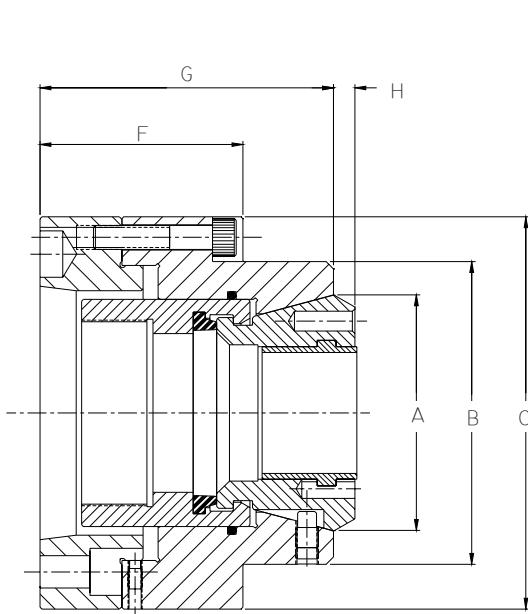

FIGURE 1

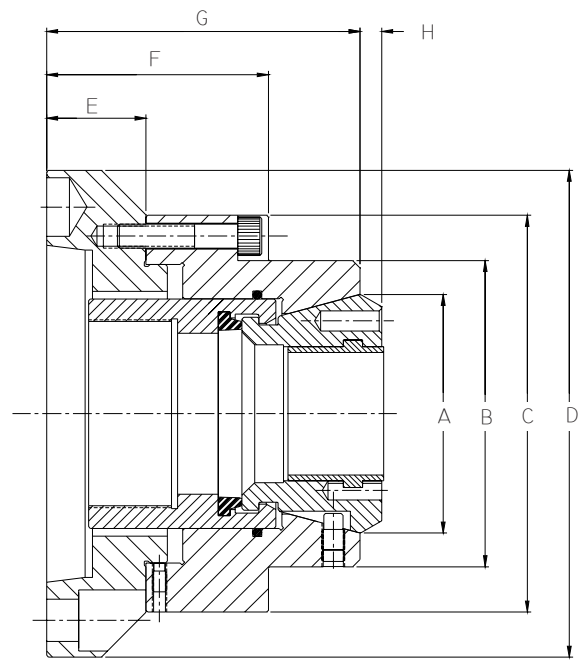

FIGURE 2

CB-ND/S Collet Chucks - Dead Length Design

In the CB-ND/S series collet chuck, the master collet is coupled to the chuck body and remains stationary as the tapered seat moves forward during clamping. This design keeps the collet in a fixed Z axis position as the chuck is actuated, and does not create a pull back effect on the bar.



CB-ND/S Features

- *Dead Length* design produces no pull back on the workpiece
- Low profile OD and short overall length provides increased tool clearance and maximum utilization of the machine's Z axis travel compared to conventional master collet chucks
- Radial adjusting screws for fast, accurate adjustment
- Lubricated-for-life design requires minimal maintenance
- All components hardened and precision ground for highest accuracy and long life
- Vulcanized master collet and rubber face seal inside chuck body eliminates chip and coolant contamination
- Spindle speeds up to 6,000 rpm

CB-ND/S Specifications

Chuck Model	CB65-ND/S20	CB65-ND/S22	CB80-ND/S26	CB80-ND/S30	CB100-ND/S35
Master Collet Model	S-20	S-22	S-26	S-30	S-35
Through Capacity	2.000"	2.250"	2.625"	3.000"	3.500"
	50.8mm	57.2mm	66.7mm	76.2mm	88.9mm
Clamping Range	+/- .020"	+/- .020"	+/- .020"	+/- .020"	+/- .040"
	+/- 0.5mm	+/- 0.5mm	+/- 0.5mm	+/- 0.5mm	+/- 1mm
Draw Tube Stroke	.160"	.160"	.160"	.160"	.275"
	4mm	4mm	4mm	4mm	7mm
Max. Draw Bar Force	10,095 lbs	10,095 lbs	11,980 lbs	11,980 lbs	14,580 lbs
	4,590 kg	4,590 kg	5,450 kg	5,450 kg	6,630 kg
Max. Clamping Force	18,170 lbs	18,170 lbs	21,560 lbs	21,560 lbs	26,240 lbs
	8,260 kg	8,260 kg	9,820 kg	9,820 kg	11,930 kg
Max Speed	6,000 rpm	6,000 rpm	5,000 rpm	5,000 rpm	4,500 rpm
Net Weight	32.6 lbs	32.6 lbs	46.3 lbs	46.3 lbs	82.5 lbs
	14.8 kg	14.8 kg	21.1 kg	21.1 kg	37.5 kg

Standard Equipment

CB-ND/S collet chucks are supplied with a vulcanized master collet, spindle adapter plate, blank draw tube connector, mounting screws and collet installation fixture. Threaded draw tube connectors for specific machine configurations are furnished at no additional charge if draw tube dimensions are provided with your purchase order. See page 13 for spindle and draw tube data sheet.

CB-ND/S Dimensions

Chuck Model	Fig.	Spindle Nose	A	B	C	D	E	F
CB65-ND/140/S20	1	140mm	3.886"	6.480"	-	-	4.780"	.354"
			98.7mm	164.6mm	-	-	121.4mm	9mm
CB65-ND/A5/S20	1	A2-5	3.886"	6.480"	-	-	4.780"	.354"
			98.7mm	164.6mm	-	-	121.4mm	9mm
CB65-ND/A6/S20	1	A2-6	3.886"	6.480"	-	-	5.330"	.354"
			98.7mm	164.6mm	-	-	135.4mm	9mm
CB65-ND/A5/S22	1	A2-5	3.886"	6.480"	-	-	4.780"	.354"
			98.7mm	164.6mm	-	-	121.4mm	9mm
CB65-ND/A6/S22	1	A2-6	3.886"	6.480"	-	-	5.330"	.354"
			98.7mm	164.6mm	-	-	135.4mm	9mm
CB80-ND/A6/S26	1	A2-6	4.500"	7.700"	-	-	4.955"	.180"
			114.3mm	195.6mm	-	-	125.9mm	4.6mm
CB80-ND/A8/S26	2	A2-8	4.500"	7.700"	9.200"	1.105"	5.210"	.180"
			114.3mm	195.6mm	233.7	28.1mm	132.3mm	4.6mm
CB80-ND/A6/S30	1	A2-6	4.500"	7.700"	-	-	4.955"	.180"
			114.3mm	195.6mm	-	-	125.9mm	4.6mm
CB80-ND/A8/S30	2	A2-8	4.500"	7.700"	9.200"	1.105"	5.210"	.180"
			114.3mm	195.6mm	233.7	28.1mm	132.3mm	4.6mm
CB100-ND/A8/S35	1	A2-8	5.704"	9.350"	-	-	6.600"	.040"
			144.8mm	237.5mm	-	-	167.6mm	1mm
CB100-ND/A11/S35	2	A2-11	5.704"	9.350"	10.950"	2.000"	7.440"	.040"
			144.8mm	237.5mm	278.1mm	50.8mm	189mm	1mm

Spindle adapter plates other than those listed above are quoted upon request.

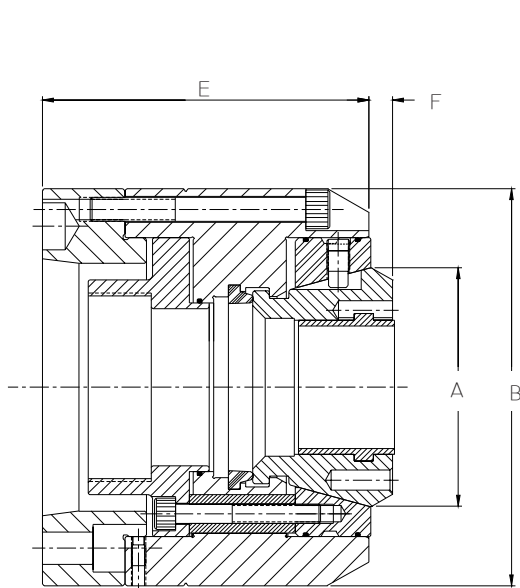

FIGURE 1

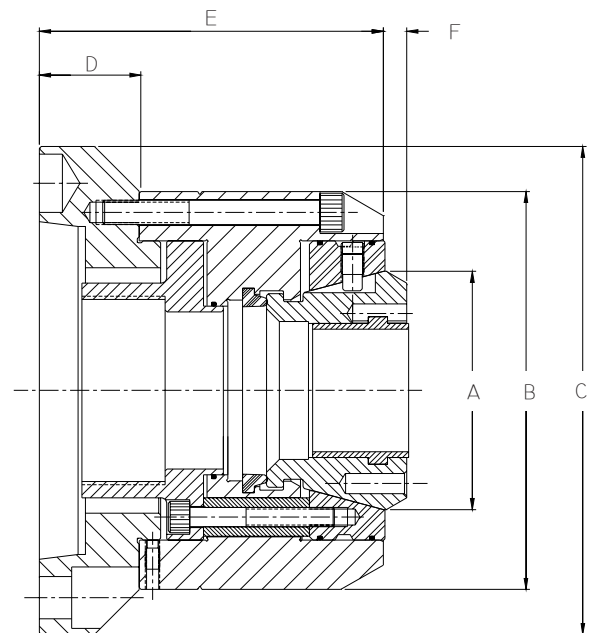

FIGURE 2

CB-NDR/S Collet Chucks - Pull to Close Dead Length Design for Servo Bar Loaders

The CB-NDR/S series collet chuck is a new patented *Dead Length* design for use with servo stop bar loaders. The chuck is actuated as the draw tube is pulled into the machine spindle. The master collet is coupled to the chuck body and remains stationary as the tapered seat moves forward during clamping. This feature keeps the collet in a fixed Z axis position, and since the draw tube is moving into the spindle, the bar remains positioned against the servo stop.



CB-NDR/S Features

- *Pull to Close Dead Length* design produces no pull back and will not push the bar off the servo stop
- Radial adjusting screws for fast, accurate adjustment
- Lubricated-for-life design requires minimal maintenance
- All components hardened and precision ground for highest accuracy and long life
- Vulcanized master collet and rubber face seal inside chuck body eliminates chip and coolant contamination
- Spindle speeds up to 6,000 rpm

CB-NDR/S Specifications

Chuck Model	CB65-NDR/S20	CB65-NDR/S22	CB80-NDR/S26	CB80-NDR/S30
Master Collet Model	S-20	S-22	S-26	S-30
Through Capacity	2.000" 50.8mm	2.250" 57.2mm	2.625" 66.7mm	3.000" 76.2mm
Clamping Range	+/- .020" +/- 0.5mm	+/- .020" +/- 0.5mm	+/- .020" +/- 0.5mm	+/- .020" +/- 0.5mm
Draw Tube Stroke	.480" 12.2mm	.480" 12.2mm	.480" 12.2mm	.480" 12.2mm
Max. Draw Bar Force	7,060 lbs 3,210 kg	7,060 lbs 3,210 kg	8,404 lbs 3,820 kg	8,404 lbs 3,820 kg
Max. Clamping Force	18,170 lbs 8,260 kg	18,170 lbs 8,260 kg	21,560 lbs 9,820 kg	21,560 lbs 9,820 kg
Max Speed	6,000 rpm	6,000 rpm	5,000 rpm	5,000 rpm
Net Weight	37.9 lbs 17.2 kg	37.9 lbs 17.2 kg	57.8 lbs 26.2 kg	57.8 lbs 26.2 kg

Standard Equipment

CB-NDR/S collet chucks are supplied with a vulcanized master collet, spindle adapter plate, blank draw tube connector, mounting screws and collet installation fixture. Threaded draw tube connectors for specific machine configurations are furnished at no additional charge if draw tube dimensions are provided with your purchase order. See page 13 for spindle and draw tube data sheet.

CB-NDR/S Dimensions

Chuck Model	Fig.	Spindle Nose	Dimensions					
			A	B	C	D	E	F
CB65-NDR/140/S20	1	140mm	3.886"	6.480"	-	-	5.978"	.354"
			98.7mm	164.6mm	-	-	151.8mm	9mm
CB65-NDR/A5/S20	1	A2-5	3.886"	6.480"	-	-	6.175"	.354"
			98.7mm	164.6mm	-	-	156.8mm	9mm
CB65-NDR/A6/S20	1	A2-6	3.886"	6.480"	-	-	6.725"	.354"
			98.7mm	164.6mm	-	-	170.8mm	9mm
CB65-NDR/A5/S22	1	A2-5	3.886"	6.480"	-	-	6.175"	.354"
			98.7mm	164.6mm	-	-	156.8mm	9mm
CB65-NDR/A6/S22	1	A2-6	3.886"	6.480"	-	-	6.725"	.354"
			98.7mm	164.6mm	-	-	170.8mm	9mm
CB80-NDR/A6/S26	1	A2-6	4.500"	7.700"	-	-	6.245"	.180"
			114.3mm	195.6mm	-	-	158.6mm	4.6mm
CB80-NDR/A8/S26	2	A2-8	4.500"	7.700"	9.200"	1.105"	6.500"	.180"
			114.3mm	195.6mm	233.7mm	28.1mm	165.1mm	4.6mm
CB80-NDR/A6/S30	1	A2-6	4.500"	7.700"	-	-	6.245"	.180"
			114.3mm	195.6mm	-	-	158.6mm	4.6mm
CB80-NDR/A8/S30	2	A2-8	4.500"	7.700"	9.200"	1.105"	6.500"	.180"
			114.3mm	195.6mm	233.7mm	28.1mm	165.1mm	4.6mm

Spindle adapter plates other than those listed above are quoted upon request.

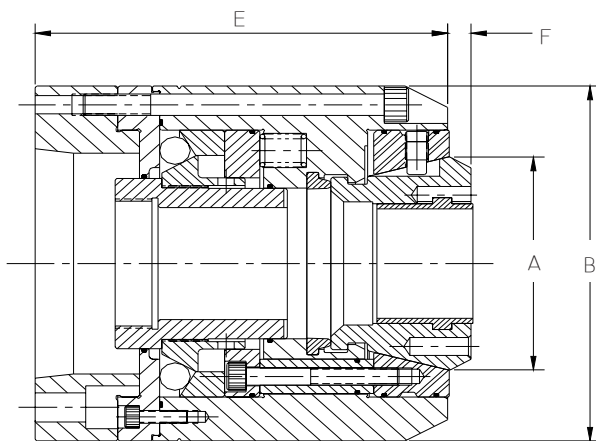

FIGURE 1

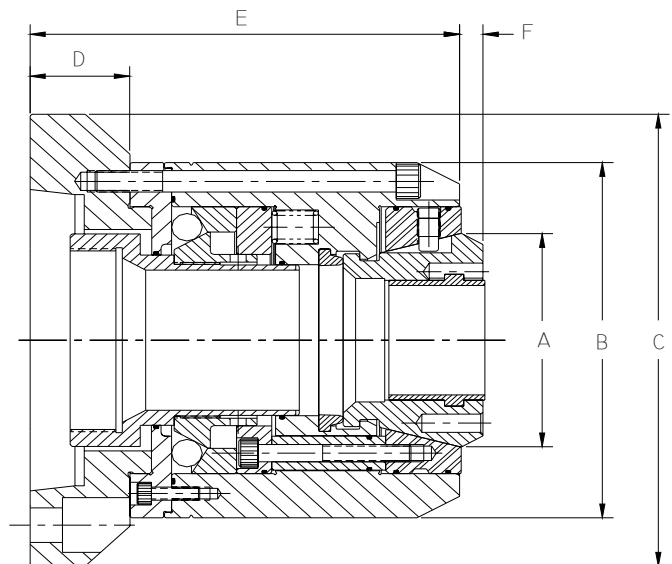

FIGURE 2

CB-NS/S Collet Chucks - Sub Spindle Design

The CB-NS/S series is a low profile dead length collet chuck designed especially for sub spindle applications. The master collet is coupled to the chuck body and remains stationary as the tapered seat moves forward during clamping. This design keeps the collet in a fixed Z axis position as the chuck is actuated, and does not create a pull back effect on the bar.



CB-NS/S Features

- *Dead Length* design produces no pull back on the workpiece
- Reduced chuck OD for maximum clearance on sub spindles
- Short overall length provides increased tool clearance and maximum utilization of the machine's Z axis travel compared to conventional master collet chucks
- Internal mounting for ejectors and stops
- All components hardened and precision ground for highest accuracy and long life
- Vulcanized master collet and rubber face seal inside chuck body eliminates chip and coolant contamination
- Spindle speeds up to 6,000 rpm

CB-NS/S Specifications

Chuck Model	CB46-NS/S16	CB65-NS/S20	CB65-NS/S22
Master Collet Model	S-16	S-20	S-22
Through Capacity	1.625"	2.000"	2.250"
	41.3mm	50.8mm	57.2mm
Clamping Range	+/- .020"	+/- .020"	+/- .020"
	+/- 0.5mm	+/- 0.5mm	+/- 0.5mm
Draw Tube Stroke	.160"	.160"	.160"
	4mm	4mm	4mm
Max. Draw Bar Force	7,850 lbs	10,095 lbs	10,095 lbs
	3,580 kg	4,590 kg	4,590 kg
Max. Clamping Force	9,420 lbs	12,115 lbs	12,115 lbs
	4,280 kg	5,510 kg	5,510 kg
Max Speed	6,000 rpm	5,000 rpm	5,000 rpm
Net Weight	14.7 lbs	25.1 lbs	25.1 lbs
	6.7 kg	11.4 kg	11.4 kg

Standard Equipment

CB-NS/S collet chucks are supplied with a vulcanized master collet, spindle adapter plate, blank draw tube connector, mounting screws and collet installation fixture. Threaded draw tube connectors for specific machine configurations are furnished at no additional charge if draw tube dimensions are provided with your purchase order. See page 13 for spindle and draw tube data sheet.

CB-NS/S Dimensions

Chuck Model	Fig.	Spindle Nose	Spindle							
			A	B	C	D	E	F	G	H
CB46-NS/110/S16	1	110mm	3.095"	4.625"	5.000"	-	-	2.329"	3.899"	.055"
			78.6mm	117.5mm	127mm	-	-	59.2mm	99mm	1.4mm
CB46-NS/140/S16	1	140mm	3.095"	4.625"	5.000"	5.950"	.750"	2.360"	3.930"	.055"
			78.6mm	117.5mm	127mm	151.1mm	19mm	59.9mm	99.8mm	1.4mm
CB46-NS/A5/S16	2	A2-5	3.095"	4.625"	5.000"	5.250"	.780"	2.360"	3.930"	.055"
			78.6mm	117.5mm	127mm	164.6mm	19.8mm	59.9mm	99.8mm	1.4mm
CB65-NS/140/S20	1	140mm	3.886"	5.500"	6.250"	-	-	1.588"	4.538"	.354"
			98.7mm	139.7mm	158.7mm	-	-	40.3mm	115.3mm	9mm
CB65-NS/A5/S20	2	A2-5	3.886"	5.500"	6.250"	-	-	1.790"	4.740"	.354"
			98.7mm	139.7mm	158.7mm	-	-	45.3mm	120.3mm	9mm
CB65-NS/A6/S20	2	A2-6	3.886"	5.500"	6.250"	6.480"	.875"	1.790"	4.740"	.354"
			98.7mm	139.7mm	158.7mm	164.6mm	22.2mm	45.3mm	120.3mm	9mm
CB65-NS/A5/S22	2	A2-5	3.886"	5.500"	6.250"	-	-	1.790"	4.740"	.354"
			98.7mm	139.7mm	158.7mm	-	-	45.3mm	120.3mm	9mm
CB65-NS/A6/S22	2	A2-6	3.886"	5.500"	6.250"	6.480"	.875"	1.790"	4.740"	.354"
			98.7mm	139.7mm	158.7mm	164.6mm	22.2mm	45.3mm	120.3mm	9mm

Spindle adapter plates other than those listed above are quoted upon request.

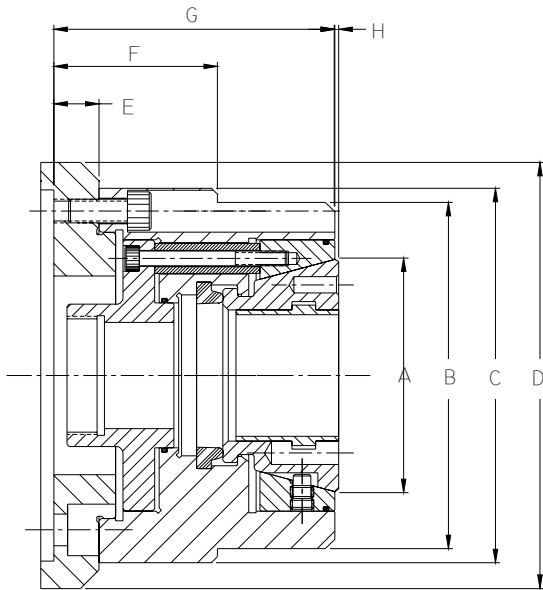

FIGURE 1

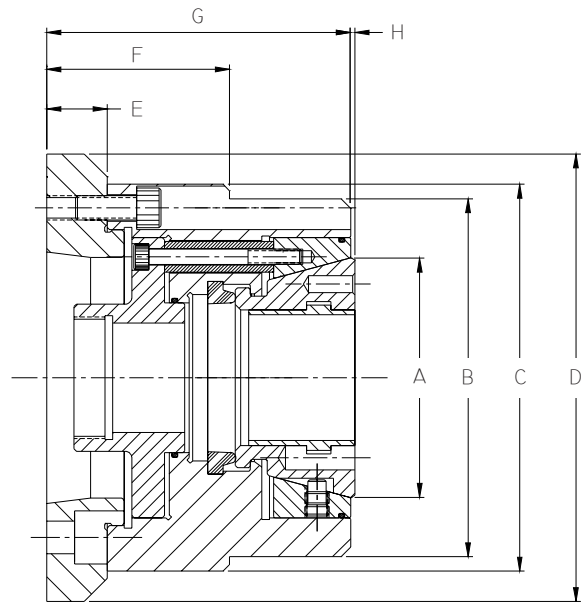
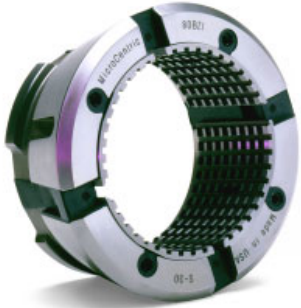

FIGURE 2

Collet Chuck Accessories

Master Collets



Collet Pad Model	Master Collet Model	Chuck Model
S-16	SK46BZI/S16	CB46 Series
S-20	SK65BZI/S20	CB65 Series
S-22	SK65BZI/S22	CB65 Series
S-26	SK80BZI/S26	CB80 Series
S-30	SK80BZI/S30	CB80 Series
S-35	SK100BZI/S35	CB100 Series

Master collets are made from hardened alloy steel, and are precision ground to very close tolerances to assure best accuracy and long term performance. Master collets are supplied with clamp screws.

Collet Installation Fixtures



Fixture Model	Master Collet Model	Type	Chuck Model
CM46	S-16	Manual	CB46 Series
CM65	S-20 & S-22	Manual	CB65 Series
CM80	S-26 & S-30	Manual	CB80 Series
CP100	S-35	Pneumatic	CB100 Series

Collet installation fixtures are used to insert and remove the master collet from the collet chuck. Removal of the master collet is necessary only when removing the chuck from the machine or during maintenance when the collet chuck is being cleaned.

Ejectors for Sub Spindle Collet Chucks

Ejector Model	Chuck Model
AW-CB46/S	CB46-NS/S
AW-CB65/S	CB65-NS/S

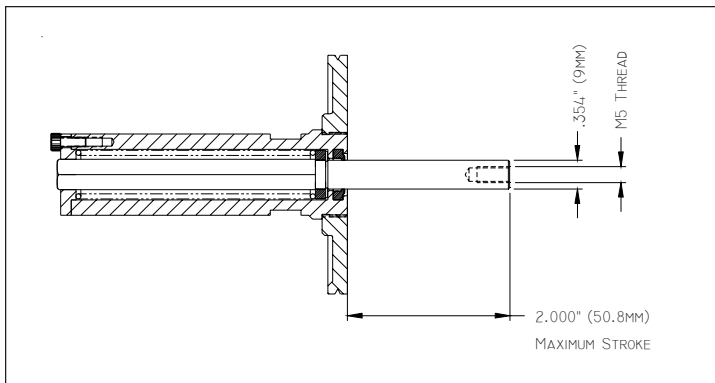

Ejectors for sub spindle collet chucks are mounted inside the chuck behind the master collet. It is not necessary to remove the collet chuck from the machine to install the ejector.

Spindle & Draw Tube Data Sheet

Company	
Chuck Model	
Date	
Ref. No.	

Contact us at **1-800-573-1139** if you have any questions about completing this data sheet.

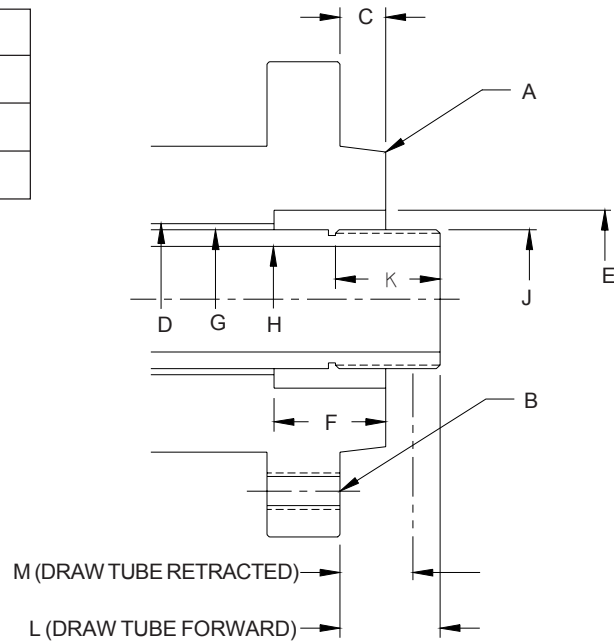

Machine Make		
Machine Model		
Machine Serial No.		
A* taper size		
B mounting thread		
C length of pilot		
D through hole diameter		
E ID counterbore or taper (if any)		
F depth of counterbore (if any)		
G OD of draw tube	H ID of draw tube	
J thread data	thread diameter	
	thread pitch	
	<input type="checkbox"/> right hand	<input type="checkbox"/> left hand
	<input type="checkbox"/> OD thread	<input type="checkbox"/> ID thread
K length of thread		
L** forward position		
M retracted position		

* For machines with a straight spindle pilot a detail drawing of the spindle must be submitted

** Positive (+) indicates draw tube is in front of the spindle face (as shown)

Negative (-) indicates draw tube is behind the spindle face



MicroCentric Corp • 25 So. Terminal Drive, Plainview, NY 11803 • USA
Tel: 516-349-7220 • Fax: 516-349-9354 • e-mail: sales@MicroCentric.com

1-800-573-1139

www.MicroCentric.com