



*Installation and Operating Manual
for LDN High Speed Air Cylinders*

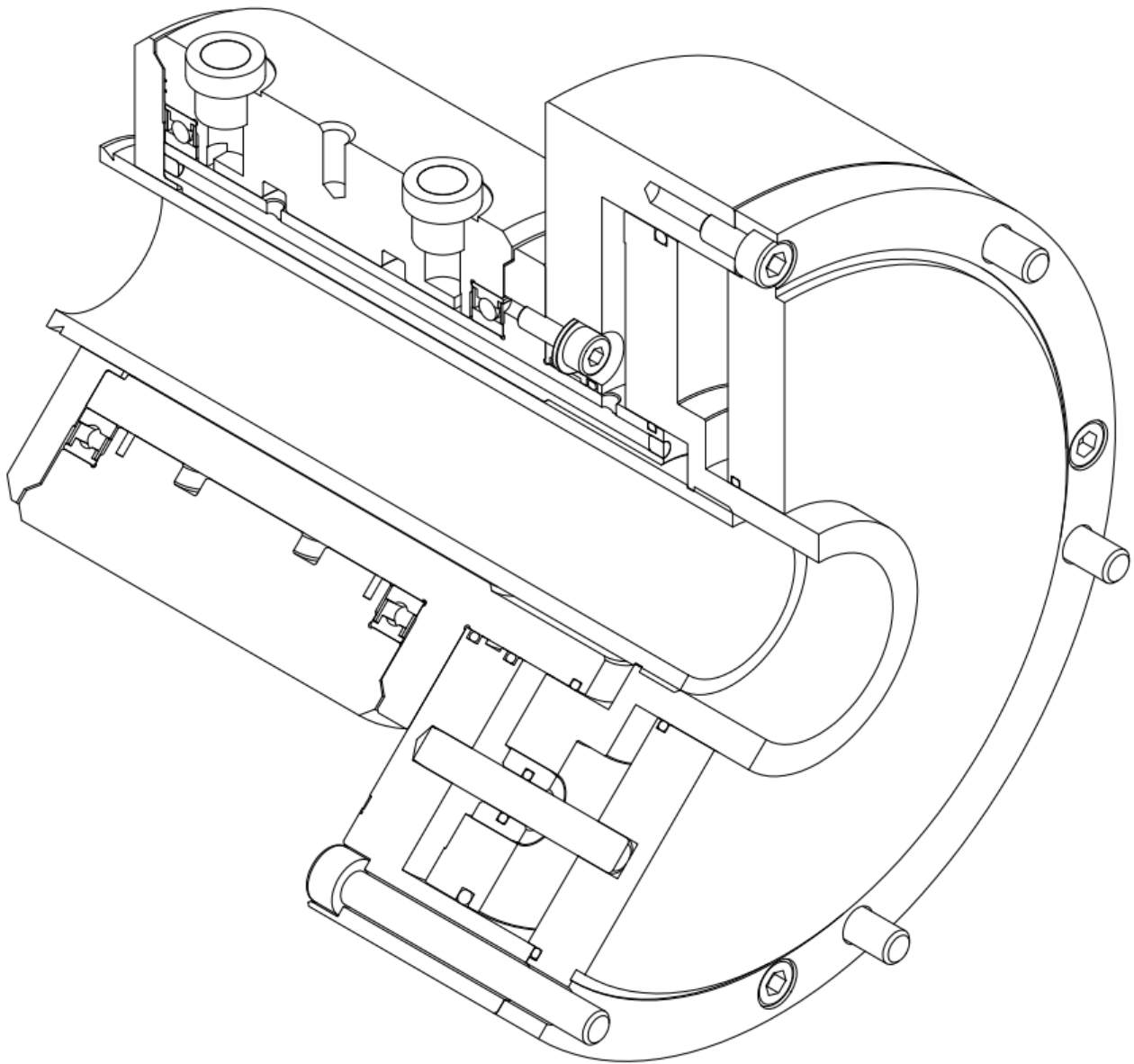

TABLE OF CONTENTS

1.0 Contact & Service Information	2
2.0 Introduction	3
3.0 Precautions for Safe Operation	4
4.0 Recommended Tightening Torque for Mounting Screws	5
5.0 Air Cylinder Models & Specifications	6
5.1 LDN Standard Through Hole Models.....	6
5.2 LDN/RE Through Hole Models with Stroke Control.....	6
5.3 LDN/LV Through Hole Models with Lock Valves and Optional Stroke Control.....	6
5.4 LDN/A Adjustable Draw Tube Models	6
6.0 Assembly Drawing and Parts List	7
7.0 Installation Diagram	8
8.0 Air Supply and Lubrication.....	8
9.0 Mounting Procedure	9

1.0 CONTACT AND SERVICE INFORMATION

Manufactured by:
MicroCentric Corp.
Plainview, NY USA
www.microcentric.com

Service in North America:
MicroCentric Corp.
25 South Terminal Drive
Plainview, NY 11803 USA
Toll-Free: 1-800-573-1139
Phone: 1-516-349-7220
E-mail: sales@microcentric.com

Service in Europe:
MicroCentric GmbH
Ringstrasse 134
70839 Gerlingen
Germany
Phone: 49-71156-17819-00
E-mail: info@microcentric.de

Service in Asia:
Dynamic Tools Corp.
7-4-6 Seikadai, Seika-cho
Sorakugun
Kyoto 6190238 Japan
Phone: 81-774-98-0518
E-mail: dynex@earth.email.ne.jp

2.0 INTRODUCTION

MicroCentric LDN Series High Speed Air Cylinders are produced to the highest standards of precision and accuracy. LDN Air Cylinders are an advanced design which feature a precision rotary air bearing. If this unit is correctly installed and properly maintained, it will provide years of trouble-free operation and performance.

The information in this manual, if followed, will enable you to obtain maximum performance and life from MicroCentric air cylinders. Please keep this manual handy for easy reference. This manual is also available for download at microcentric.com.



SAFETY ALERT SYMBOL

This symbol is used to call attention to items that could be dangerous to you or persons using this equipment. Please read these messages and follow these instructions and safety regulations before use.



DANGER

Indicates an imminent hazardous condition which, if not avoided, could result in serious injury or death.



WARNING

Indicates a potentially hazardous condition which, if not avoided, could result in serious injury or death.



CAUTION

Indicates a potentially hazardous condition which, if not avoided, could result in injury.

IMPORTANT

Instructions for optimum performance and avoiding errors or misuse of chuck.

3.0 PRECAUTIONS FOR SAFE OPERATION



DANGER



Switch off power to the machine before installing or changing the air cylinder.

- The machine spindle may inadvertently be switched on, potentially causing serious injury to the operator.



DANGER



Always supply dry, clean (filtered) air to actuate the air cylinder.

- Supplying clean air to the air cylinder prevents contamination of the rotary air bearing which could lead to seizure of the assembly. The sealed bearing design does not require oil in the air supply.



WARNING



Do not run the air cylinder without supplying air pressure to the rotary air bearing assembly.

- The rotary air bearing will run hot, which over a period of time can damage the ball bearings and lead to potential seizure of the assembly.



WARNING



Make certain the mounting bolts are securely tightened to the recommended torque values.

- The air cylinder could become loose during operation.



WARNING



Never attempt to operate a machine tool while under the influence of drugs or alcohol.

- Damage to the machine, tooling, and chuck, or serious injury to the operator could result.



CAUTION



When the machine has been sitting for a period of time (especially overnight), run spindle at 100 rpm for 5 minutes.

Running the cylinder at high speeds when the unit is cold can damage the rotary air bearing assembly.

4.0 RECOMMENDED TIGHTENING TORQUE FOR MOUNTING SCREWS

SOCKET HEAD CAP SCREW SIZE (CLASS 12.9)	M5	M6	M8	M10	M12	M14	M16	M20
TIGHTENING TORQUE [N*m]	7.5	13	33	73	107	171	250	402
TIGHTENING TORQUE [lb*ft]	5.5	9.6	24	54	79	126	184	297

5.0 AIR CYLINDER MODELS & SPECIFICATIONS

5.1 LDN STANDARD THROUGH HOLE MODELS

Size	Cylinder Model	Through Hole	Piston Stroke	Max. Air Pressure	Draw Tube Force*	Max. rpm	Weight
6"	LDN-150	1.102"	.394"	150 psi	1,640 lb	6,000	12 lb
152 mm		28mm	10mm	10.5 kg/cm ²	745 kg		5.5 kg
8"	LDN-200	1.102"	.710"	150 psi	2,920 lb	5,000	23 lb
203 mm		28mm	18 mm	10.5 kg/cm ²	1,327 kg		10.5 kg
10"	LDN-250	1.102"	.710"	150 psi	5,200 lb	4,000	32 lb
254 mm		28mm	18 mm	10.5 kg/cm ²	2,364 kg		14.5 kg

*at 100psi (7 kg/cm²)

5.2 LDN/RE THROUGH HOLE MODELS WITH STROKE CONTROL

Size	Cylinder Model	Through Hole	Piston Stroke	Max. Air Pressure	Draw Tube Force*	Max. rpm	Weight
6"	LDN-150/RE	1.102"	.394"	150 psi	1,640 lb	6,000	12 lb
152 mm		28mm	10mm	10.5 kg/cm ²	745 kg		5.5 kg
8"	LDN-200/RE	1.102"	.710"	150 psi	2,920 lb	5,000	23 lb
203 mm		28mm	18 mm	10.5 kg/cm ²	1,327 kg		10.5 kg
10"	LDN-250/RE	1.102"	.710"	150 psi	5,200 lb	4,000	32 lb
254 mm		28mm	18 mm	10.5 kg/cm ²	2,364 kg		14.5 kg

*at 100psi (7 kg/cm²)

5.3 LDN/LV THROUGH HOLE MODELS WITH LOCK VALVES AND OPTIONAL STROKE CONTROL

Size	Cylinder Model	Through Hole	Piston Stroke	Max. Air Pressure	Draw Tube Force*	Max. rpm	Weight
7"	LDN-178/RE	1.102"	.394"	150 psi	2,520 lb	6,000	24 lb
178mm		28mm	10mm	10.5 kg/cm ²	1140 kg		11 kg

*at 100psi (7 kg/cm²)

5.4 LDN/A ADJUSTABLE DRAW TUBE MODELS

Size	Cylinder Model	Through Hole	Piston Stroke	Max. Air Pressure	Draw Tube Force*	Max. rpm	Weight
6"	LDN/A-150	1.063"	.394"	150 psi	1,640 lb	6,000	15.4
152 mm		27mm	10mm	10.5 kg/cm ²	745 kg		7 kg

*at 100psi (7 kg/cm²)

6.0 ASSEMBLY DRAWING AND PARTS LIST

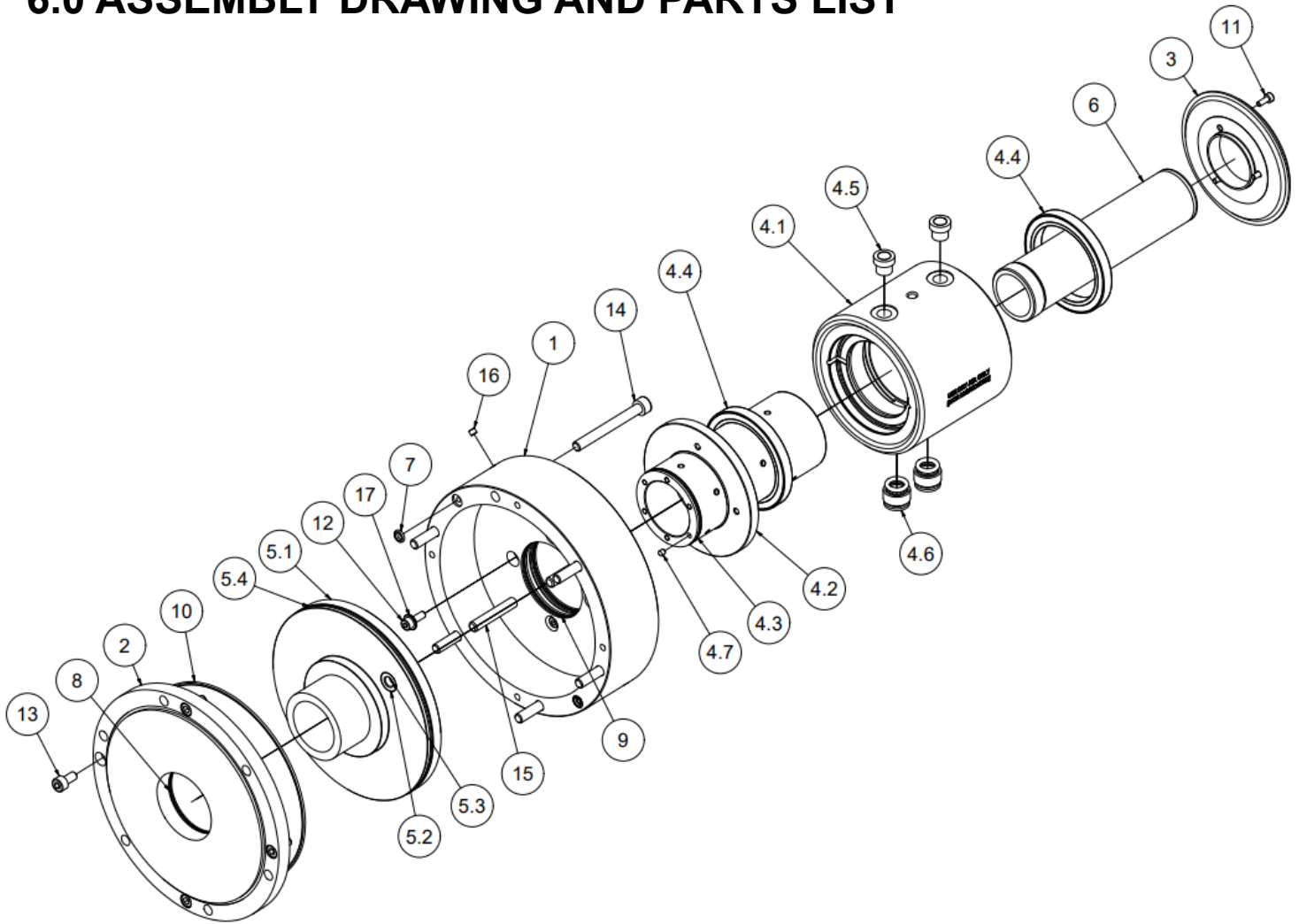

ITEM	QTY	DESCRIPTION
1	1	CYLINDER
2	1	BACK COVER
3	1	END CAP
4	1	BEARING ASSY LDN150 SEALED
4.1	1	SLEEVE LDN-150 SEALED
4.2	1	JOURNAL
4.3	1	O-RING
4.4	2	BALL BEARING
4.5	2	BREATHER VENT
4.6	2	FITTING INSERT
4.7	12	EXPANSION PLUG
5	1	PISTON ASSY
5.1	1	PISTON
5.2	2	BUSHING

ITEM	QTY	DESCRIPTION
5.3	2	O-RING
5.4	1	O-RING
6	1	EXTENSION TUBE
7	2	O-RING
8	1	O-RING
9	2	O-RING
10	1	O-RING
11	3	SOCKET HEAD CAP SCREW
12	4	SOCKET HEAD CAP SCREW
13	4	SOCKET HEAD CAP SCREW
14	6	SOCKET HEAD CAP SCREW
15	2	DOWEL
16	2	EXPANSION PLUG
17	4	SEALING WASHER

7.0 INSTALLATION DIAGRAM

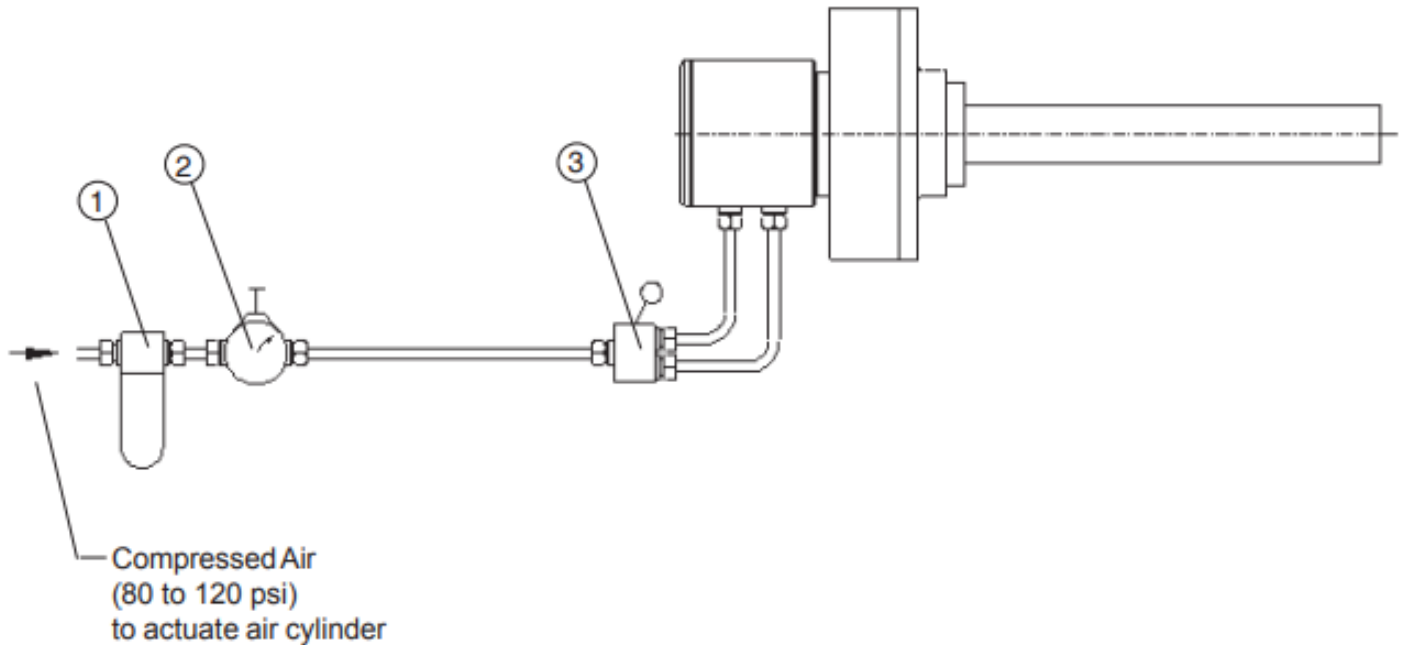

ITEM	DESCRIPTION	NOTES
1	AIR FILTER	Change every 6 months.
2	PRESSURE REGULATOR	Max. 100 psi (7kg/cm ²). Min. 20 psi (1.5 kg/cm ²).
3	VALVE	Manual or electric solenoid.

8.0 AIR SUPPLY AND LUBRICATION

LDN Air Cylinders will provide many hours of continuous, trouble-free operation if the unit is properly installed and the following precautions are observed:

1. The air that is supplied to actuate the air cylinder must be dry (without lubrication) and filtered.
2. Always run the air cylinder with air pressure to the rotary air bearing assembly. Air flow is required for the proper function of the air bearing, and will also dissipate any heat generated during operation.
3. Change the filter element in the air filter unit at least every 6 months.



WARNING

Always supply dry, filtered air to the cylinder.



WARNING

Never run the air cylinder without air pressure applied to the unit.

9.0 MOUNTING PROCEDURE

MicroCentric LDN Air Cylinders usually require an adapter plate to mount to the rear of the machine spindle. Refer to the assembly drawing in Section 6.0 to familiarize yourself with the unit's components.

1. First mount the adapter plate to the rear of the machine spindle. Clean all surfaces of both the spindle and mounting plate. Make sure surfaces are free of dirt, nicks, and burrs that would prevent the proper seating of the adapter plate. Tighten the mounting screws alternately and equally to the recommended torque for the screw size used. Do not over-tighten.
2. Use a dial indicator to check the runout of the mounting face and pilot diameter of the adapter plate. The runout of the pilot diameter should be within .0004" (0.010 mm). The runout of the mounting face must be within .0002" (0.050 mm).
3. Thread the draw tube into air cylinder. Use a strap wrench to tighten the draw tube. A removable thread locking compound may be used to make sure the thread does not loosen during operation. Never use a permanent thread locking compound.
4. Mount the air cylinder to the adapter plate. Make sure all surfaces are free of chips, dirt, nicks, and burrs that could prevent the proper seating. Do not tighten the (6) mounting screws fully at this time.
5. Measure the runout of the OD of the air bearing housing in the middle with a dial indicator. Adjust the runout to within .0008" (0.020 mm).
6. Tighten the (6) mounting screws alternately and equally to the recommended torque for the screw size used. Do not over-tighten.
7. Check the runout of the air bearing housing again to verify it has not changed as the mounting screws were tightened.
8. Mount an anti rotation bracket to the machine, and insert an M6 screw through the bracket and thread it into the tapped hole on the OD of the housing. The anti rotation screw should not exert side load or drag which would prevent the free rotation of the air bearing assembly.
9. Referring to the installation diagram in Section 7.0, connect the 2 air lines which actuate the air cylinder into the 1/4"-27 NPT fittings on the rotary air bearing. The inner port (closest to the cylinder) is for clamping; the outer port (at the rear) is for unclamping.



CAUTION

Do not apply excessive torque to the mounting screws when mounting the adapter plate or air cylinder.



CAUTION

The radial runout of the sleeve should not exceed .0008" (0.020mm) TIR.



WARNING

The air fittings are installed at the factory and should never be overtightened as the air bearing housing can be distorted.



WARNING

The anti-rotation screw cannot exert side load or drag on the air bearing housing. Minimum clearance .020" (0.5mm) per side.

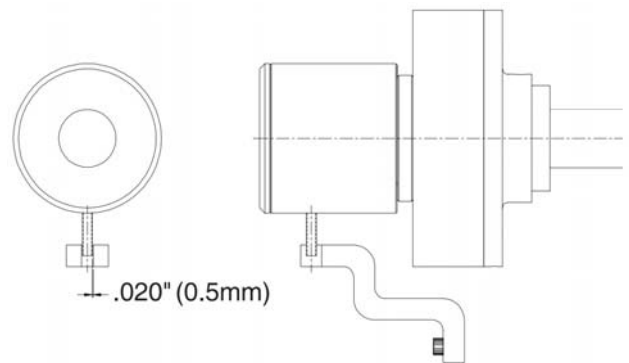

Figure 9.1



MicroCentric Corp • 25 So. Terminal Drive, Plainview, NY 11803 USA
Tel: 516-349-7220 • Fax: 516-349-9354 • e-mail: sales@microcentric.com

1-800-573-1139
www.microcentric.com